

Feed Modules VKK

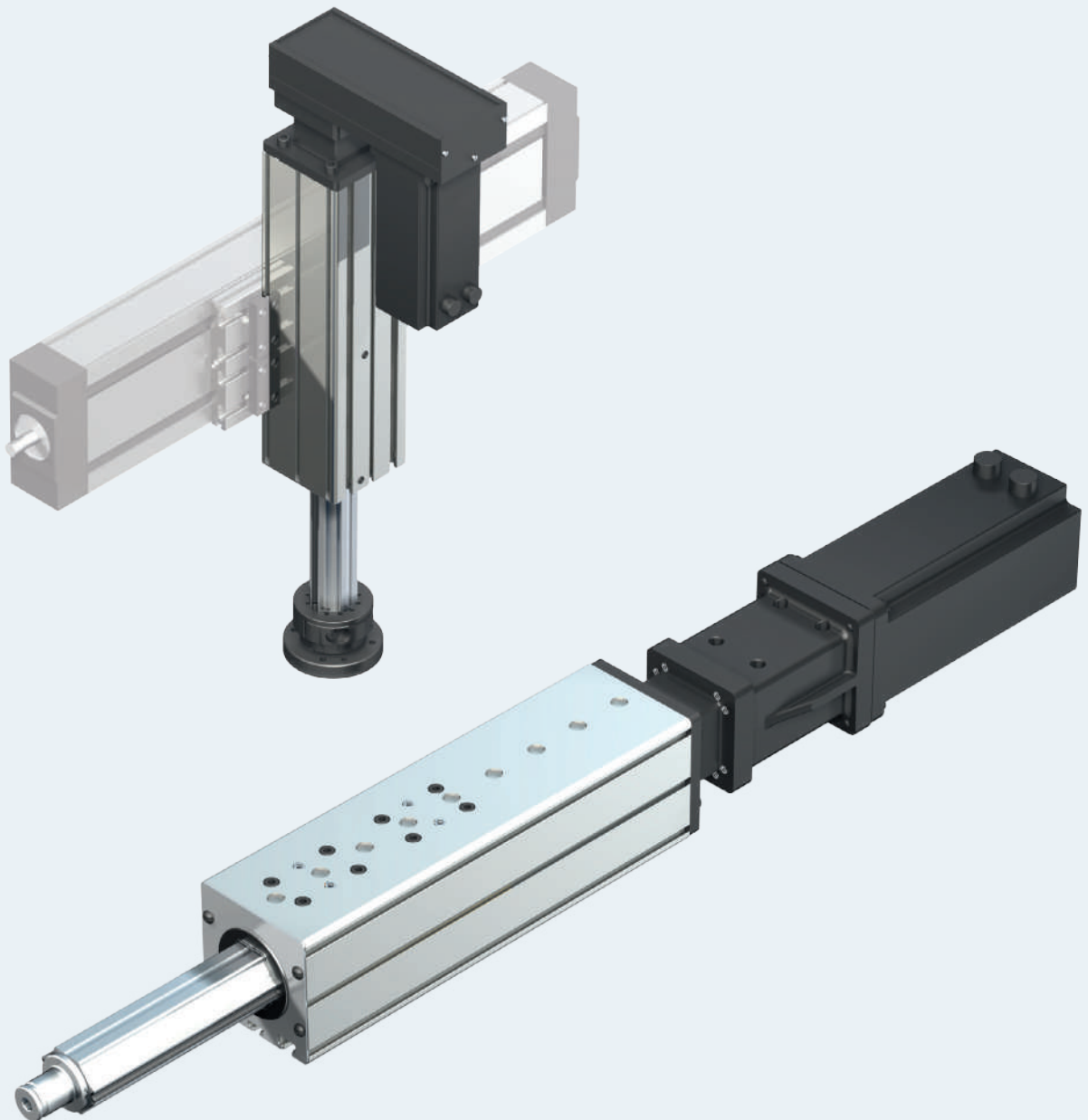

Identification system for short product names

Short product name	=	Example: VKK - 070 - NN - 1
System	=	<u>F</u> eed Modules
Size	=	050 / <u>070</u> / 100
Version	=	<u>S</u> tandard version
Generation	=	Product generation <u>1</u>

Changes/additions at a glance

- New catalog number
- New short product name
- Revised technical data table and drive data structure
- "Calculation" section revised
- "Configuration, ordering, dimension drawings, options" section revised
- "Attachments and accessories" (motors according to customer specification, switch mounting, sensors, etc.) section added

Contents

Product overview	Product Description	4	
	Structural Design	6	
Technical data	General technical data	8	
	Drive data	10	
	Rigidity	12	
Calculation	Calculation principles	16	
	Drive dimensioning	19	
	Result	27	
Configuration and ordering	VKK-050	Configuration and ordering	28
		Dimension drawings	30
	VKK-070	Configuration and ordering	32
		Dimension drawings	34
	VKK-100	Configuration and ordering	36
		Dimension drawings	38
Attachments and accessories	Mounting	40	
	Mounting Accessories	42	
	Connection Elements	44	
	Attachment kits for motors according to customer specification	46	
	IndraDyn S - MSK servo motor	48	
	IndraDyn S - servo motors MSM	50	
	Switch Mounting Arrangements	52	
	Sensors	54	
	EasyHandling	68	
Service and information	Operating conditions	72	
	Parameterization (start-up)	73	
	Lubrication and maintenance	74	
	Documentation	76	
	Ordering example VKK-100	78	
	Ordering example	80	
	Request or order	81	
	Additional information	82	
	Notes	83	

Product Description

Rexroth Feed Modules VKK are precise, ready-to-install linear motion systems that combine high performance with space-saving dimensions.

Characteristic features

- ▶ Rexroth Feed Modules VKK are especially suitable for handling tasks requiring high precision as well as high thrust and torque transfer capabilities.
- ▶ Because of their low moved mass, Feed Modules VKK are ideal for vertical motion in z-axes.

Structural design

- ▶ Extremely compact extruded aluminum profile (frame) with zero-clearance Ball Rail System
- ▶ Integrated precision ball screw drive (BASA) in tolerance grade 7 with zero-backlash nut system
- ▶ Fixed bearing end block made of aluminum

Attachments

- ▶ Maintenance-free servo drives with or without brake
- ▶ Motor mount and coupling or timing belt side drive for motor attachment
- ▶ Switch
- ▶ Bellows

- ▶ Without motor attachment
- ▶ Motor attachment
 - via timing belt side drive
 - via motor mount

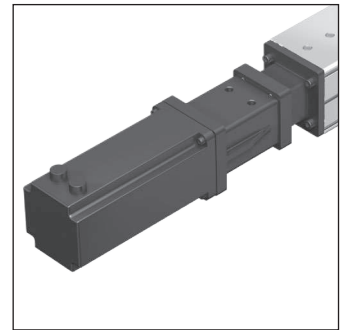
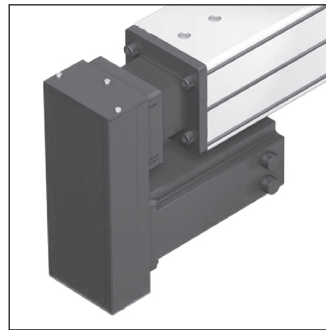
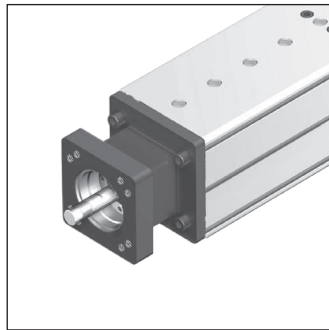

- ▶ Thrust rod with adapter flange for customer attachments
- ▶ Centering holes for positive-locking connections with good reproducibility and simplified installation
- ▶ Bellows cover

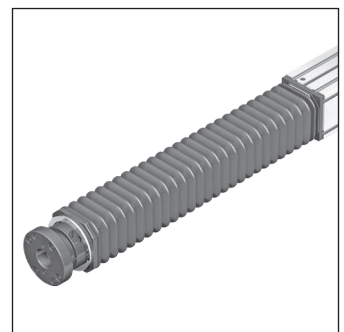
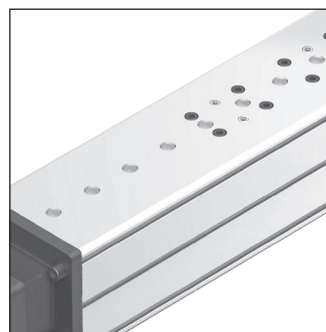
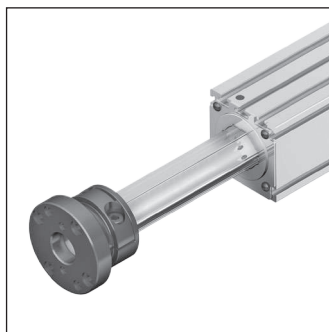

Further highlights

- ▶ Optimal travel performance, high load capacities and high rigidity due to integrated, zero-clearance ball rail system
- ▶ Space-saving design
- ▶ Ball screw drive with zero-backlash nut system assures high positioning accuracy and repeatability
- ▶ Easy motor attachment due to locating feature and fastening threads
- ▶ Encapsulated guideway
- ▶ Switches positionable over the entire travel range
- ▶ Switch activation via internal magnets
- ▶ Allows easy installation of various attachments
- ▶ Fully compatible with the EasyHandling system
- ▶ Positive-locking connection technology with centering rings

Nameplate

- ▶ On the nameplate you will find technical data for start-up. With these technical data and the EasyWizard software, starting up linear motion systems becomes easier, faster and more effective than ever before.

Rexroth		Bosch Rexroth AG D-97419 Schweinfurt Made in Germany					
MNR: R12345678		TYP: VKK		FD: 483		(7210)	
CS: 9876543210		20		07			
s_{max} (mm)	u (mm/U)	v_{max} (m/s)	a_{max} (m/s ²)	$M1_{max}$ (Nm)	d	i	
-	-	-	-	-	-	-	

Structural Design

- 1 Ball screw drive with zero-backlash nut
- 2 Fixed bearing end block
- 3 Frame
- 4 Thrust rod
- 5 Mounting interface for adapter flange
- 6 Front seal

Attachments

- 7 Magnetic field sensor
- 8 Motor
- 9 Motor mount and coupling
- 10 Timing belt side drive

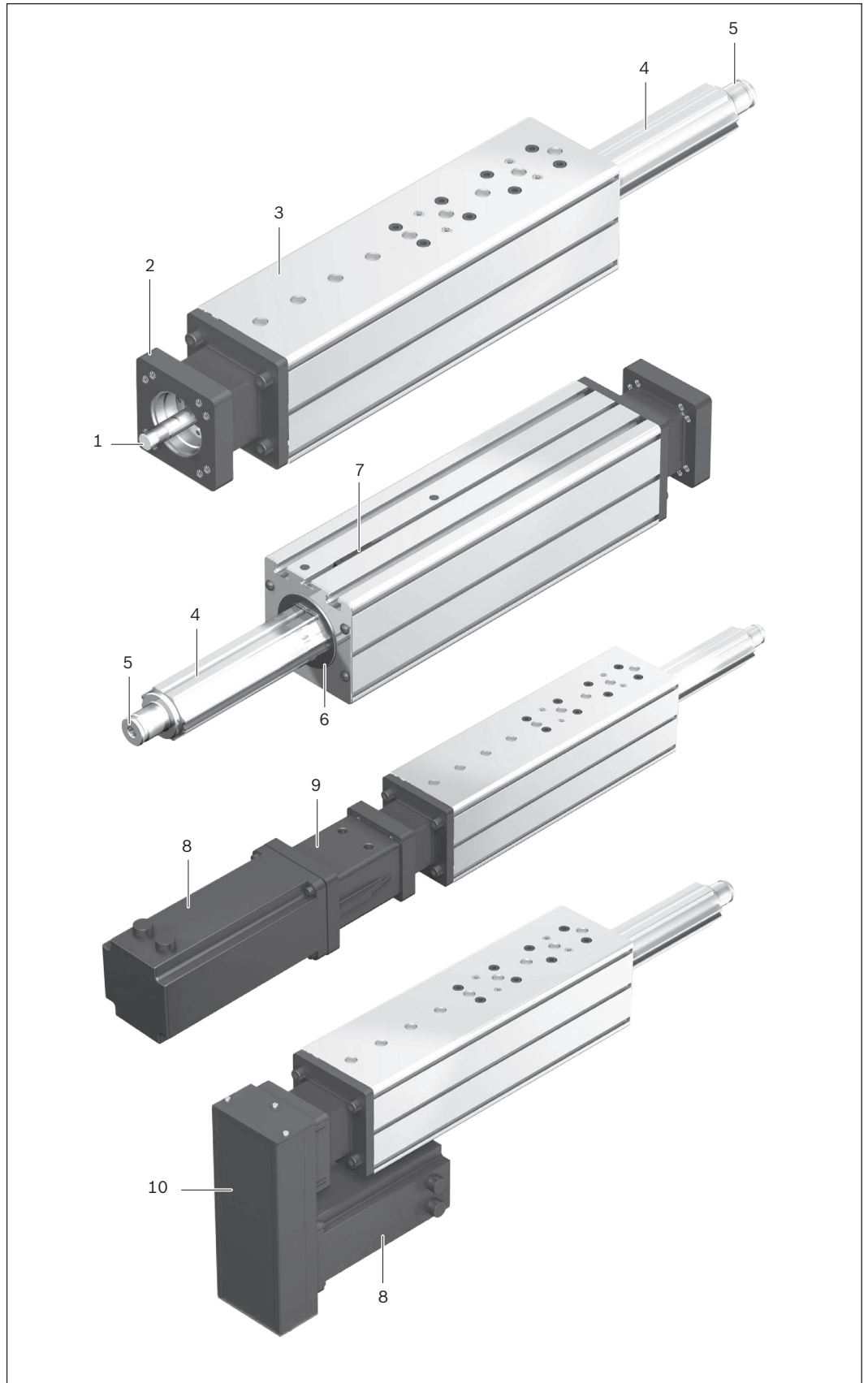

Motor mount and coupling

A motor can be attached to all Feed Modules by means of a motor mount and coupling.

The motor mount serves to fasten the motor to the Feed Module and acts as a closed housing for the coupling. The motor's drive torque is transmitted stress-free through the coupling to the Feed Module's screw journal.

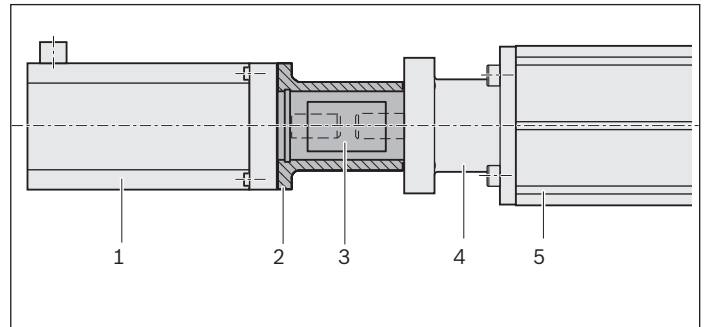

Timing belt side drive

All feed modules offer the option of attaching the motor via a side drive with timing belt.

This results in a shorter overall length compared to a motor attachment via motor mount and coupling.

The space-saving, closed housing protects the belt and secures the motor. Various gear ratios are also available:

- $i = 1 : 1$
- $i = 1 : 1.5$
- $i = 1 : 2$

The timing belt side drive can be mounted in four different directions.

- 1** Motor
- 2** Motor mount
- 3** Coupling
- 4** Fixed bearing end block
- 5** Feed Module
- 6** Cover
- 7** Drawn, anodized aluminum profile
- 8** Toothed belt
- 9** Pre-tensioning the of the toothed belt: apply pre-tensioning force F_{pr} to motor (F_{pr} will be indicated on delivery)
- 10** Belt pulleys
- 11** Cover plate

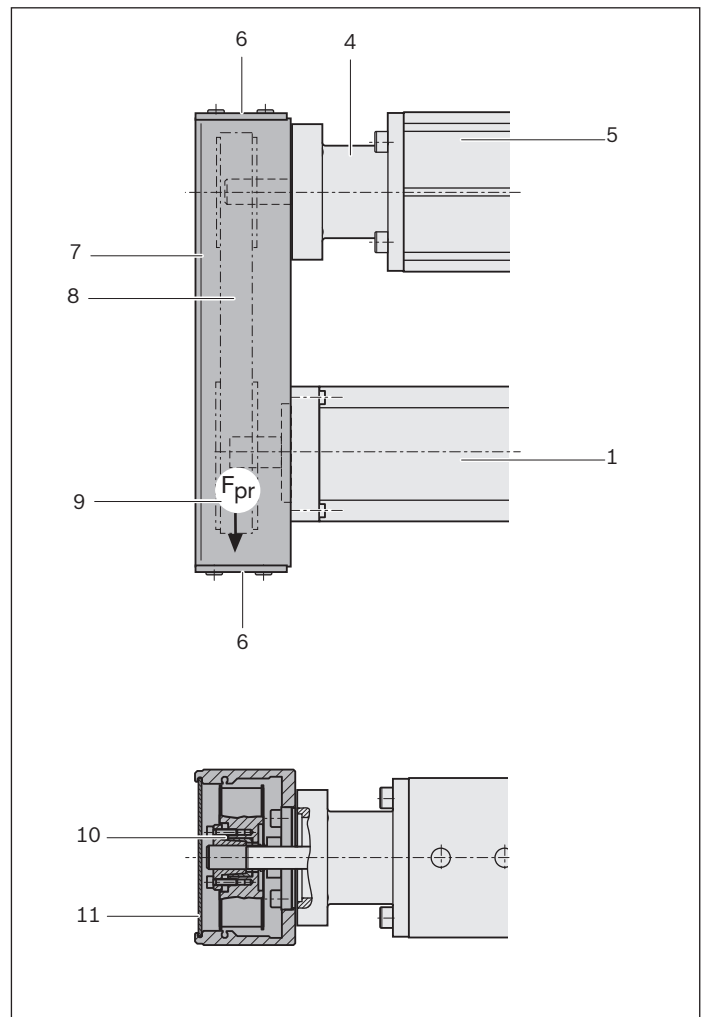

General technical data

Size	VKK-050	VKK-070	VKK-100
B (mm)	50	70	100
L¹⁾ (mm)	240	280	360
	280	320	400
	360	400	480
	480	520	600
	-	600	680
s_{max}²⁾ (mm)	378	452	476

- 1) Length
- 2) Max. travel (without bellows) at max. length.
For further travel distances, see dimension drawings.

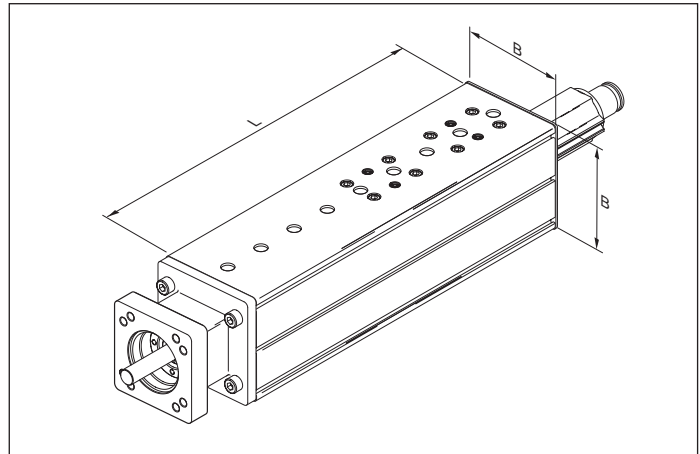

Load capacities and moments

Size	BASA	Dynamic characteristic values					Maximum permissible loads			Planar moment of inertia Thrust rod		
		Dynamic load capacity C (N)			Dynamic moments (Nm)		Maximum permissible moments (Nm)				T (mm)	
		d ₀ x P (mm)	Guideway	BASA	Fixed bearing	M _t	M _L	M _{t max}	M _{L max}	I _y (cm ⁴)		I _z (cm ⁴)
VKK-050	12 x 2	6 950	2 240	4 000	97	61	48	30	2.6	2.3		101,5
	12 x 5		3 800									
	12 x 10		2 500									
VKK-070	16 x 5	8 120	12 300	13 400	160	280	55	110	5.7	6.7	125,0	
	16 x 10		9 600									
	16 x 16		6 300									
VKK-100	20 x 5	26 000	14 300	17 900	670	1 300	100	360	12.9	16.2	167,5	
	20 x 20		13 300									
	25 x 10		15 700									

Acceptable loads

(value on the basis of past experience)

As far as the desired nominal life is concerned, loads for F_m, F_{comb} of up to about 20% of the dynamic load capacity (C) have proven acceptable. See the section on calculation principles.

Do not exceed the technical data

Note on dynamic load capacities and moments

Determination of the dynamic load capacities and moments of the guideway is based on a travel life of 100,000 m. Often only 50,000 m are actually stipulated. For comparison: Multiply values C, M_t and M_L from the table by 1.26.

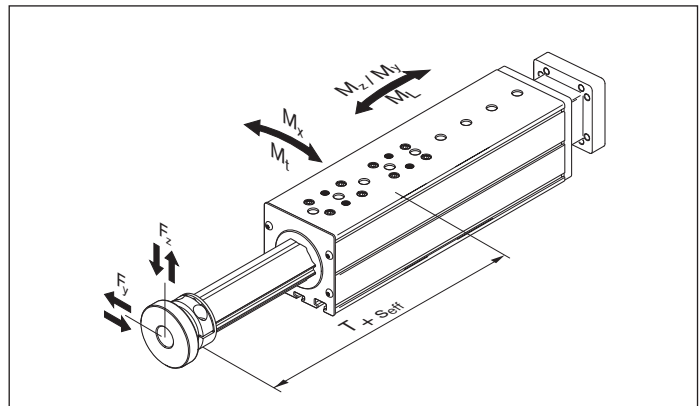

See page 12 for short product names

Mass of VKK

(without motor attachment, motor, switching system).

Size	Length L (mm)	Mass of VKK (kg)			Moved mass of system (kg)		
		Adapter flange		with	Adapter flange		with
		without	with	bellows ¹⁾	without	with	bellows ¹⁾
VKK-050	240	1.32	1.72	2.02	0.37	0.77	1.07
	280	1.47	1.87	2.17	0.42	0.82	1.12
	360	1.78	2.18	2.48	0.51	0.91	1.21
	480	2.24	2.64	2.94	0.64	1.04	1.34
VKK-070	280	2.99	3.39	3.69	0.73	1.13	1.43
	320	3.28	3.68	3.98	0.80	1.20	1.50
	400	3.88	4.28	4.58	0.92	1.32	1.62
	520	4.77	5.17	5.47	1.11	1.51	1.81
	600	5.37	5.77	6.07	1.23	1.63	1.93
VKK-100	360	8.26	8.66	9.26	1.67	2.07	2.57
	400	8.83	9.23	9.83	1.76	2.16	2.66
	480	9.98	10.38	10.98	1.93	2.33	2.83
	600	11.70	12.10	12.70	2.19	2.59	3.09
	680	12.84	13.24	13.84	2.36	2.76	3.26

¹⁾ With adapter flange

Maximum permissible drive torque M_p at the screw journal

 Requirement:
No radial load on screw journal.

Size	BASA $d_0 \times P$	M_p (Nm)	M_{RS} (Nm)	$v_{max}^{1)}$ (m/s)	$k_j \text{ fix}$	$k_j \text{ var}$	$k_j \text{ m}$	a_{max} (m/s ²)
VKK-050	12 x 2	0.79	0.22	0.23	1.193	0.013	0.101	27
	12 x 5	2.50	0.22	0.57	1.212	0.012	0.633	
	12 x 10	3.20	0.23	1.16	1.824	0.034	2.533	
VKK-070	16 x 5	4.60	0.33	0.38	4.035	0.032	0.633	27
	16 x 10	6.10	0.34	0.77	4.350	0.039	2.533	
	16 x 16	6.80	0.37	1.23	4.958	0.047	6.485	
VKK-100	20 x 5	12.64	0.52	0.32	39.342	0.086	0.633	22
	25 x 10	20.50	0.67	0.63	44.273	0.244	10.132	27
	20 x 20	25.60	0.69	1.27	46.551	0.122	2.533	27

¹⁾ For all lengths

Constants $k_j \text{ fix}$, $k_j \text{ var}$, $k_j \text{ m}$
System frictional torque M_{RS}

 The constants are required to determine the mass moment of inertia of the system J_s .

See page 12 for short product names

Drive data

Drive data for motor attachment via motor mount and coupling

Size	Motor	Coupling data		Mass Motor mount and coupling m_{fc} (kg)
		Nominal torque M_{cN} (Nm)	Mass moment of inertia J_c (10^{-6} kgm ²)	
VKK-050	MSM 019B	1.9	2.1	0.2
	MSM 031B	3.7	7.0	0.3
	MSM 031C			
VKK-070	MSM 041B	9	61	0.4
	MSM 031C	19	60	0.5
	MSK 030C			0.6
	MSK 040C			
VKK-100	MSM 041B	19	64	0.6
	MSK 050C	50	200	1.0

Drive data for motor attachment via timing belt side drive

Size	BASA $d_0 \times P$	MSM 019B								MSM 031B							
		M_{sd} (Nm)		J_{sd} (10^{-6} kgm ²)		M_{Rsd} (Nm)	m_{sd} (kg)	F (mm)	B_t	M_{sd} (Nm)		J_{sd} (10^{-6} kgm ²)		M_{Rsd} (Nm)	m_{sd} (kg)	F (mm)	B_t
		i	i	i	i					i	i	i	i				
VKK-050	12 x 2	0.79	0.53	10.7	4.1	0.10	0.28	48	6	0.79	0.53	34.8	13.0	0.15	0.63	64.5	10
	12 x 5	1.31	0.87						AT3	2.48	1.65						AT3
	12 x 10	1.31	0.87							2.70	1.80						

Size	BASA $d_0 \times P$	MSM 031C								MSM 041B							
		M_{sd} (Nm)		J_{sd} (10^{-6} kgm ²)		M_{Rsd} (Nm)	m_{sd} (kg)	F (mm)	B_t	M_{sd} (Nm)		J_{sd} (10^{-6} kgm ²)		M_{Rsd} (Nm)	m_{sd} (kg)	F (mm)	B_t
		i	i	i	i					i	i	i	i				
VKK-070	16 x 5	3.17	2.11	41.5	13.3	0.35	0.28	64.5	10	4.31	2.87	233.9	79.1	0.4	1.45	88	16
	16 x 10	3.17	2.11						AT3	5.85	3.90						AT5
	16 x 16	3.17	2.11							6.42	4.28						
VKK-100	20 x 5									8.01	5.34	240	84				
	20 x 20	-	-	-	-	-	-	-	-	8.01	5.34						
	25 x 10									8.01	5.34						

Drive data for motor attachment via timing belt side drive

Size	BASA $d_0 \times P$	MSK 030C								MSK 040C									
		M_{sd} (Nm)		J_{sd} (10^{-6} kgm ²)		M_{Rsd} (Nm)	m_{sd} (kg)	F (mm)	B_t	M_{sd} (Nm)		J_{sd} (10^{-6} kgm ²)		M_{Rsd} (Nm)	m_{sd} (kg)	F (mm)	B_t		
		i	i	i	i					i	i								
		1	1.5	1	1.5					1	1.5	1	1.5						
VKK-050	12 x 2	0.79	0.53	34.3	12.5	0.35	0.65	64.5	10 AT3	-	-	-	-	-	-	-	-		
	12 x 5	2.48	1.65																
	12 x 10	2.70	1.80																
VKK-070	16 x 5	3.17	2.11	37.3	13.4					4.31	2.87	234.4	83.6	0.4	1.42	88	16 AT5		
	16 x 10	3.17	2.11							5.85	3.90								
	16 x 16	3.17	2.11							6.42	4.28								

Size	BASA $d_0 \times P$	MSK 050C									
		M_{sd} (Nm)		J_{sd} (10^{-6} kgm ²)		M_{Rsd} (Nm)	m_{sd} (kg)	F (mm)	B_t		
		i	i	i	i						
		1	2	1	2						
VKK-100	20 x 5	10.20		5.10		1 420	230	0.45	3.2	116	25 AT5
	20 x 20	14.30		7.15							
	25 x 10	13.10		6.55							

- M_t = dynamic torsional moment
 M_L = dynamic longitudinal moment load capacity
 $M_{t \max}$ = maximum permissible torsional moment
 $M_{t \max}$ = maximum permissible longitudinal moment
 I_y = y-axis planar moment of inertia
 I_z = z-axis planar moment of inertia
 a_{\max} = max. acceleration (m/s²)
 d_0 = nominal diameter (mm)
 BASA = ball screw drive
 M_p = maximum permissible drive torque (Nm)
 M_{Rs} = frictional torque of system (Nm)
 P = lead (mm)
 v_{\max} = maximum permissible speed (m/s)
 B_t = belt type
 F = timing belt side drive width
 i = timing belt side drive gear ratio
 J_c = coupling mass moment of inertia
 J_{sd} = timing belt side drive mass moment of inertia at motor journal
 $k_{j \text{ fix}}$ = constant for fixed-length portion of mass moment of inertia
 $k_{j \text{ var}}$ = constant for variable-length portion of mass moment of inertia
 $k_{j \text{ m}}$ = constant for mass-specific portion of mass moment of inertia
 J_{sd} = reduced mass moment of inertia of timing belt side drive
 M_{Rsd} = frictional torque of timing belt side drive at motor journal
 M_{cN} = rated torque of coupling
 M_{sd} = permissible torque for system with timing belt side drive at motor journal (Nm); consider maximum permissible motor torque M_{\max}
 m_{sd} = mass of timing belt side drive
 m_{fc} = mass of motor mount and coupling

Rigidity

Rigidity of thrust rod Feed Module VKK-050 Rigidity in y-direction

Measured values

Key to graph

- a) Length = 480 mm
- b) Length = 360 mm
- c) Length = 280 mm
- d) Length = 240 mm

δ_{el} = elastic deformation (mm)
 M_L = dynamic longitudinal moment load capacity (Nm)

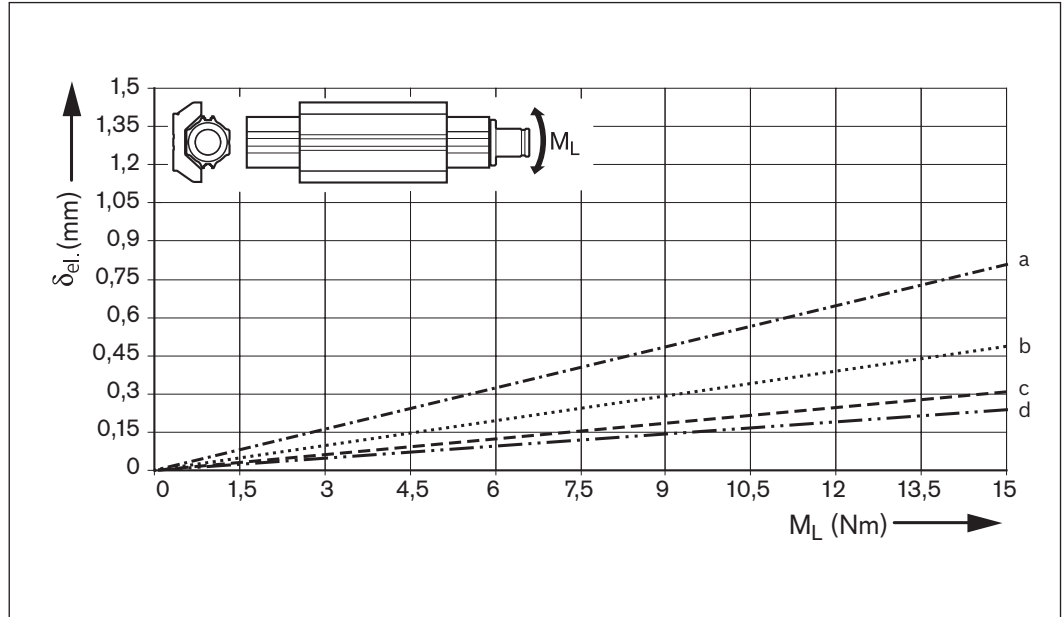

Rigidity in z-direction

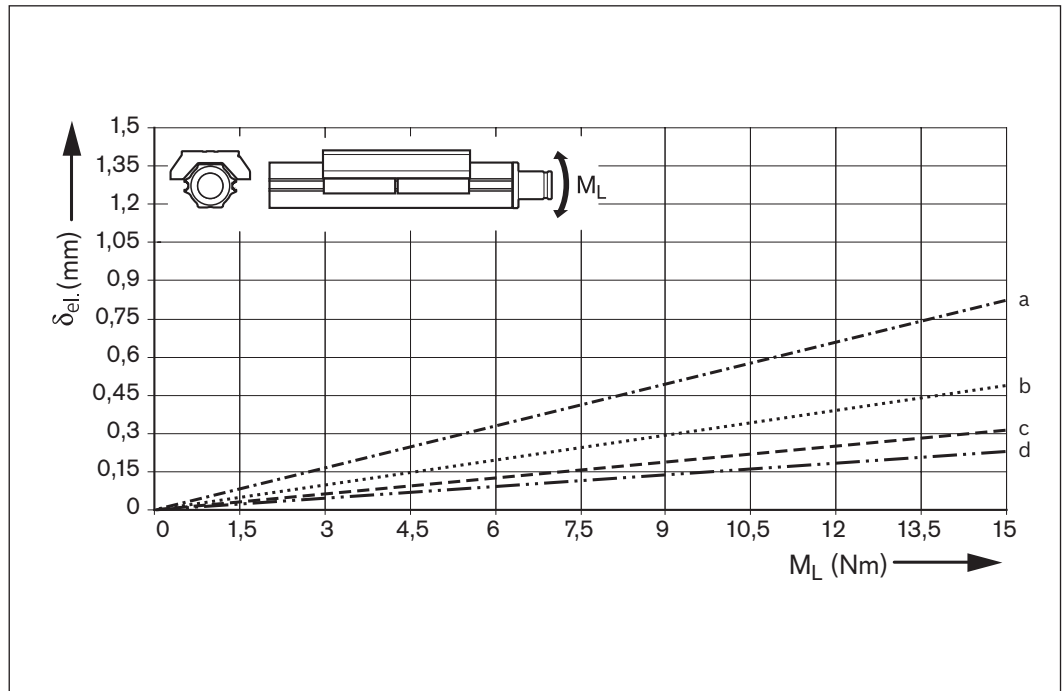

Rigidity of thrust rod
Feed Module VKK-070
Rigidity in y-direction

Measured values

Key to graph

- a)** Length = 600 mm
- b)** Length = 520 mm
- c)** Length = 400 mm
- d)** Length = 320 mm
- e)** Length = 280 mm

δ_{el} = elastic deformation (mm)
 M_L = dynamic longitudinal moment load capacity (Nm)

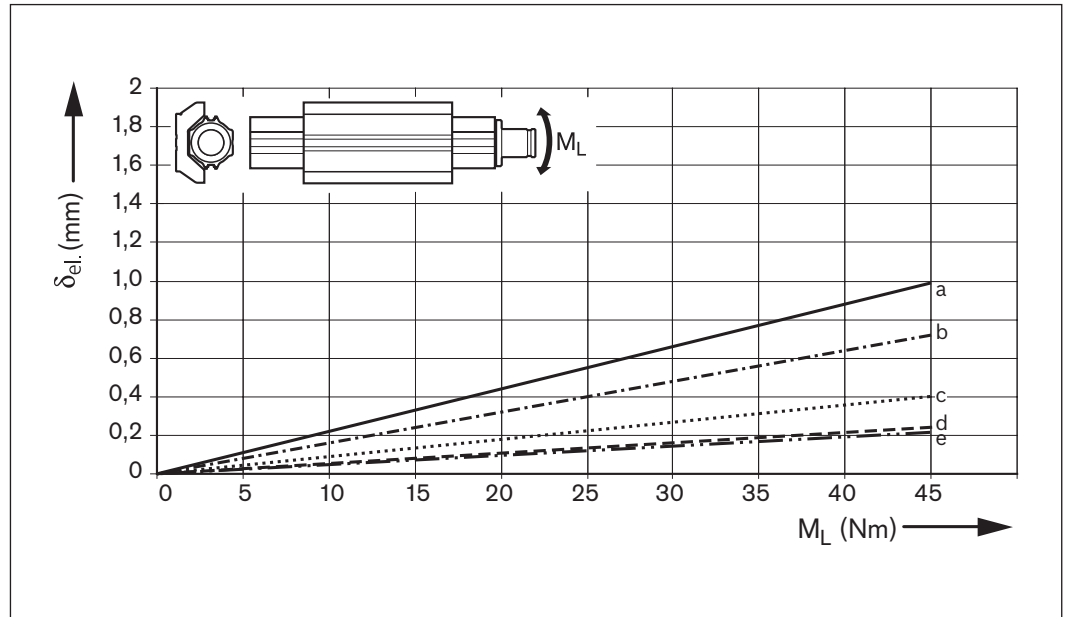

Rigidity in z-direction

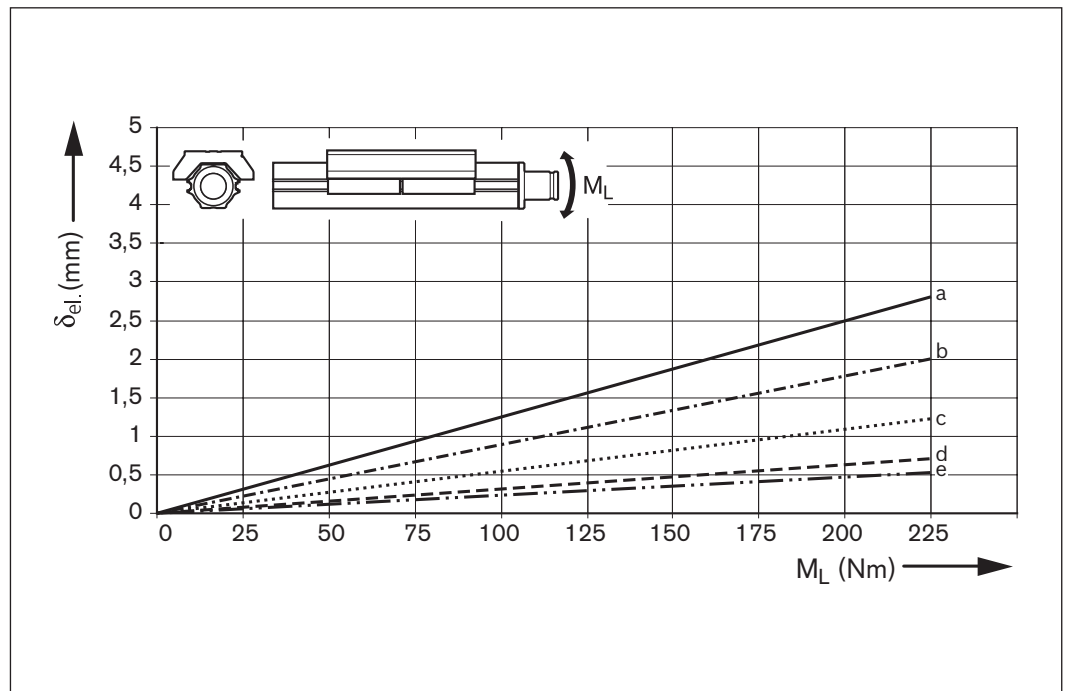

Rigidity of thrust rod
Feed Module VKK-100
Rigidity in y-direction

Measured values

Key to graph

- a) Length = 680 mm
- b) Length = 600 mm
- c) Length = 480 mm
- d) Length = 400 mm
- e) Length = 360 mm

δ_{el} = elastic deformation (mm)
 M_L = dynamic longitudinal moment load capacity (Nm)

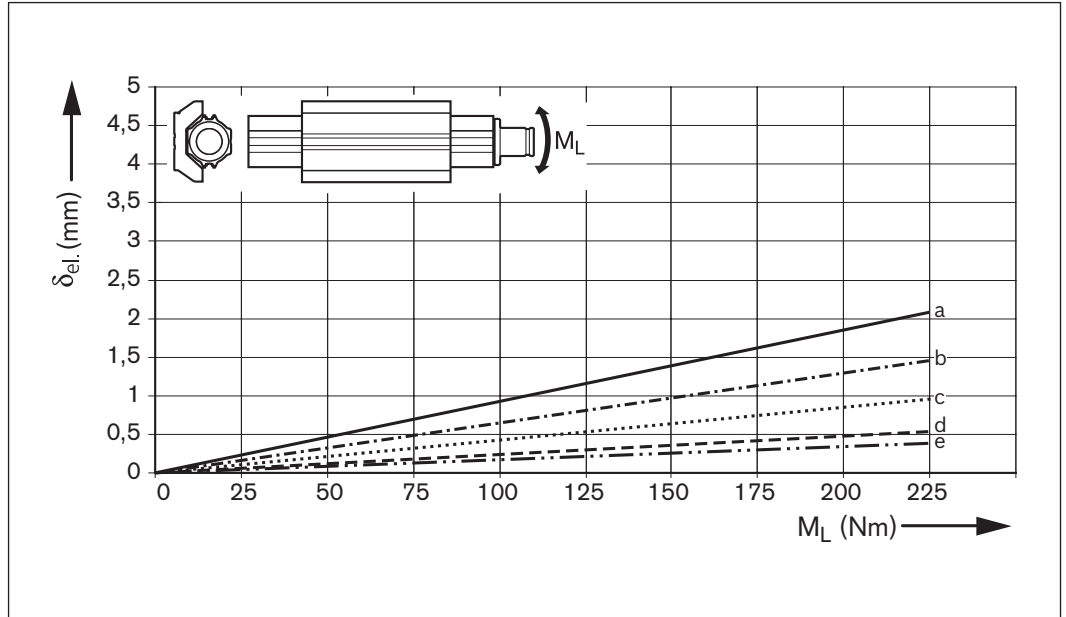

Rigidity in z-direction

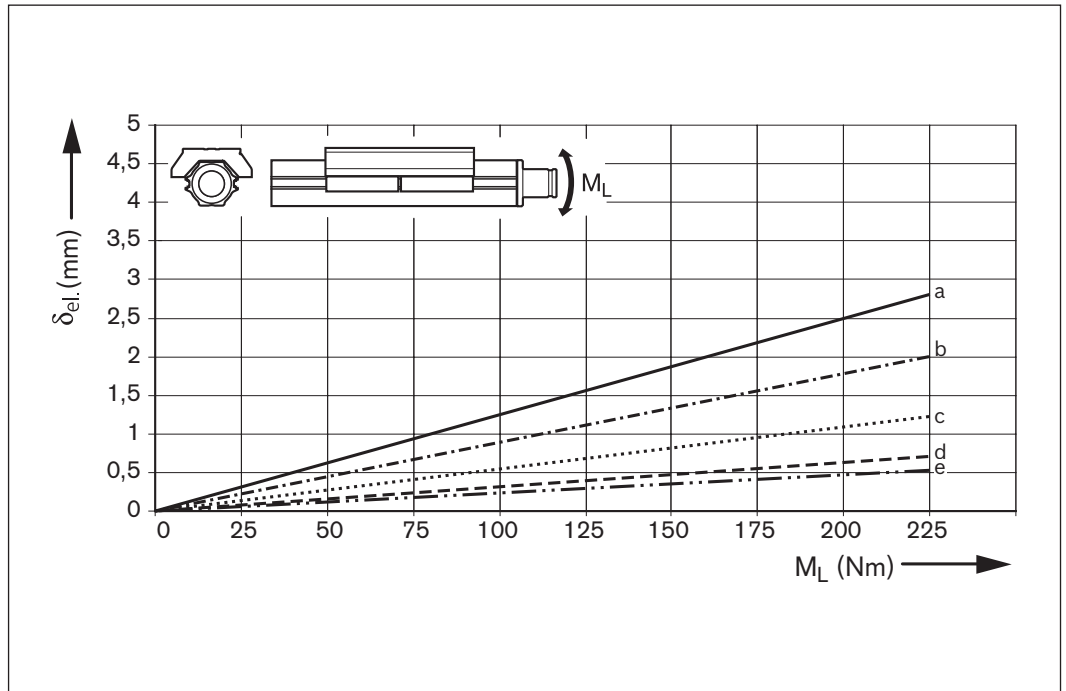

Calculation principles

Drive train

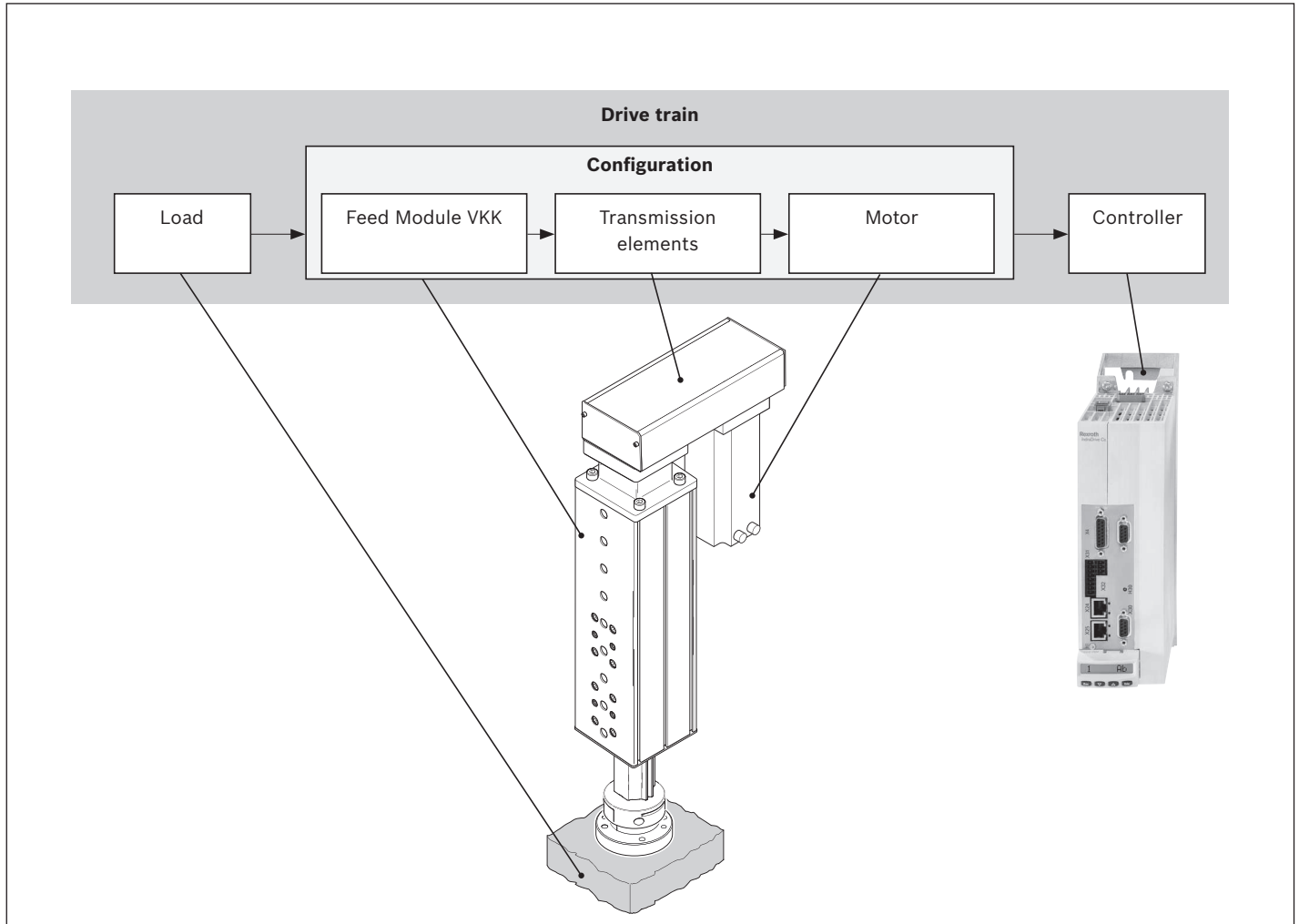

The correct dimensioning and assessment of an application requires structured consideration of the drive train as a whole. The basic element of the drive train is the configuration – made up of the linear motion system, the transmission element (coupling or timing belt side drive) and the motor – which can be ordered in that constellation in the catalog.

Maximum permissible loads

When selecting linear motion systems, it is essential to consider the upper limits for permissible loads and forces, as specified in the section “Technical Data”. The values given there are system-related. In other words, the upper limits are determined not only by the load ratings of the bearing points but also include structural design and material-related considerations.

Conditions for combined loads

$$\frac{|F_y|}{F_{y \max}} + \frac{|F_z|}{F_{z \max}} + \frac{|M_x|}{M_{x \max}} + \frac{|M_y|}{M_{y \max}} + \frac{|M_z|}{M_{z \max}} \leq 1$$

Service life

The service life of the rolling bearing points contained in a linear motion system can be calculated using the formulas given below. In a linear motion system with ball screw drive, the rolling bearing points that are relevant for the service life are the linear guide, the ball screw drive (ball nut), and the fixed bearing.

Service life of the linear guide

The linear guide of a linear motion system must bear the load and any processing forces.

Combined equivalent load on bearing of the guideway

Size	T (mm)
VKK-050	101.5
VKK-070	125.0
VKK-100	167.5

Note

The projected service life of the linear motion system is determined by the lowest of the separately calculated service life values for the linear guide, the ball screw drive and the fixed bearing.

$$F_{\text{comb}} = C \cdot \frac{|M_x|}{M_t} + C \cdot \frac{|M_y|}{M_L} + C \cdot \frac{|M_z|}{M_L}$$

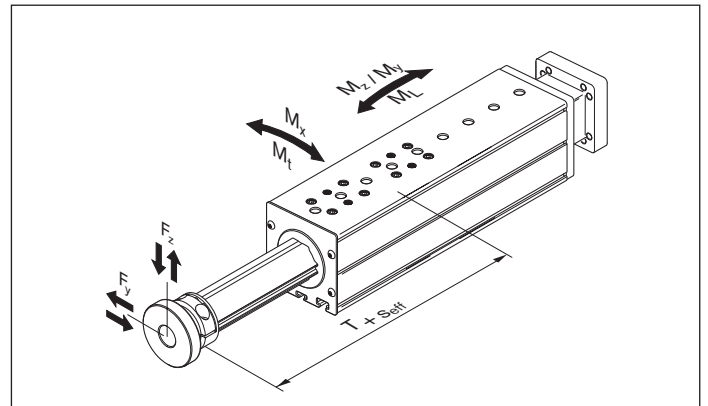

$$L = \left(\frac{C}{F_{\text{comb}}} \right)^3 \cdot 10^5$$

$$L_h = \frac{L}{3\,600 \cdot v_m}$$

Nominal life in meters

In hours

C	= dynamic load capacity	(N)
F_{comb}	= combined equivalent load on bearing	(N)
L	= nominal life	(m)
L_h	= nominal life	(h)
M_L	= dynamic longitudinal moment load capacity	(Nm)
M_t	= dynamic torsional moment	(Nm)
M_x	= dynamic torsional moment about the x-axis	(Nm)
M_y	= dynamic torsional moment about the y-axis	(Nm)
M_z	= dynamic torsional moment about the z-axis	(Nm)
v_m	= average travel speed	(m/s)
S_{eff}	= effective stroke	(mm)
$T + S_{\text{eff}}$	= center-to-center distance between runner block and mounting interface	

Calculation principles

Service life of ball screw drive or fixed bearing

Where the rotary speed and load vary, the service life must be calculated using the averages F_m and n_m .

Where the rotational speed varies, the average speed n_m is as follows:

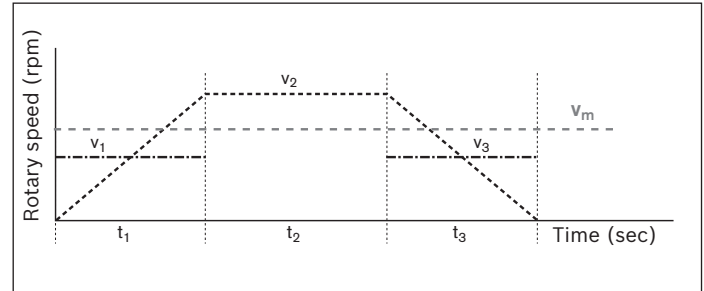

$$n_m = \frac{|n_1| \cdot t_1 + |n_2| \cdot t_2 + \dots + |n_n| \cdot t_n}{t_{total}}$$

$$t_{total} = t_1 + t_2 + \dots + t_n$$

Rotary speed in acceleration and braking phases $n_{1...n}$:

$$n_{1...n} = \frac{n_{A1...n} + n_{E1...n}}{2}$$

Where both the load and the rotational speed vary, the average load F_m is calculated as follows:

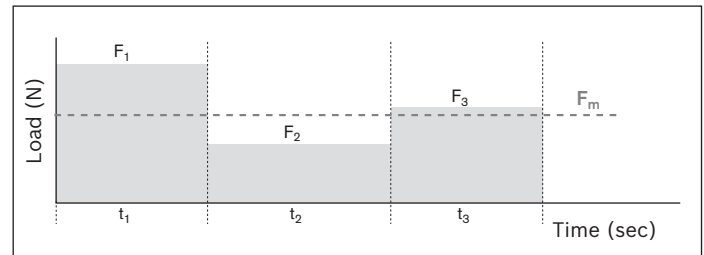

$$F_m = \sqrt[3]{|F_1|^3 \cdot \frac{|n_1|}{n_m} \cdot \frac{t_1}{t_{total}} + |F_2|^3 \cdot \frac{|n_2|}{n_m} \cdot \frac{t_2}{t_{total}} + \dots + |F_n|^3 \cdot \frac{n_n}{n_m} \cdot \frac{t_n}{t_{total}}}$$

Nominal life in revolutions

$$L = \left(\frac{C}{F_m} \right)^3 \cdot 10^6$$

In hours

$$L_h = \frac{L}{n_m \cdot 60}$$

- C = dynamic load capacity (N)
- F_1, F_2, \dots, F_n = axial load during phases 1 ... n (N)
- F_m = equivalent dynamic axial load (N)
- L = nominal life (—)
- L_h = nominal life (h)
- n_1, n_2, \dots, n_n = rotational speed in acceleration and braking phases 1 ... n (rpm)
- $n_{E1...n}$ = speed at finish in phase 1 ... n (rpm)
- n_m = average rotary speed (rpm)
- $n_{A1...n}$ = speed at start in phase 1 ... n (rpm)
- $n_{E1...n}$ = speed at finish in phase 1 ... n (rpm)
- t_1, t_2, \dots, t_n = discrete time step in phases 1 ... n (sec)
- t_{tot} = sum of the discrete time steps (sec)

Drive dimensioning

Principles

When dimensioning the drive, the drive train can be subdivided into the mechanical system and the drive itself.

The **mechanical system** includes the physical components – linear motion system and transmission elements (timing belt side drive, coupling) – and the load to be carried.

The electric **drive** is a motor/controller combination with the appropriate performance data.

The dimensioning of the electric drive is done taking the motor shaft as a reference point.

When dimensioning the drive, limit values must be taken into account as well as basic values. The limit (i.e. maximum) values must not be exceeded, in order to avoid damaging the mechanical components.

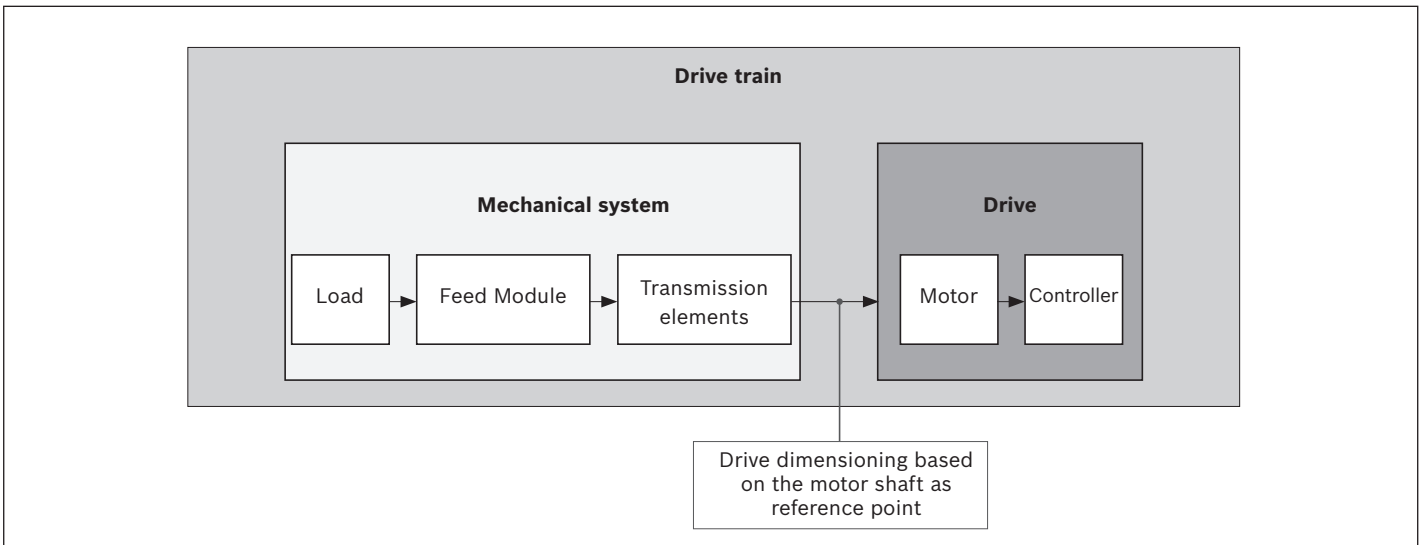

Mechanical system technical data and symbols

For each component (linear motion system, coupling, timing belt side drive), the relevant maximum permissible values must be identified for the drive torque and travel speed, as well as the basic values for frictional torque and mass moment of inertia (see “Drive Data” in the section “General Technical Data”).

The following technical data with the associated symbols are used when considering the basic mechanical system requirements in the design calculations for dimensioning the drive. The data listed in the table below can be found in the “General Technical Data” section or they are determined using the formulas described on the following pages.

	Mechanical system			
	Load	linear motion system	Transmission elements	
			Coupling	Timing belt side drive
Weight moment	(Nm)	$M_g^{6)}$	–	–
Frictional torque	(Nm)	– ⁵⁾	$M_{RS}^{3)}$	$M_{Rsd}^{3)}$
Mass moment of inertia	(kgm²)	$J_t^{1)}$	$J_s^{2)}$	$J_c^{3)}$
Max. permissible travel speed	(m/s)	–	$v_{max}^{4)}$	–
Max. permissible drive torque	(Nm)	–	$M_p^{4)}$	$M_{cN}^{3)}$
				$M_{sd}^{3)}$

- 1) Determine the value using the appropriate formula
- 2) Length-dependent value, determined using the appropriate formula
- 3) Value as per table
- 4) Length-dependent value, to be read off graph
- 5) Any additional process forces are to be taken into consideration as load moments

Drive dimensioning

Drive dimensioning based on the motor journal as reference point

For drive dimensioning, all the relevant design calculation values for the mechanical components in the drive train must be determined as they relate to – and be expressed in terms of or reduced to – the motor journal. For a combination of mechanical components within the drive train, this will result in one value for each of the following:

- ▶ Frictional torque M_R
- ▶ Mass moment of inertia J_{ex}
- ▶ Max. permissible travel speed v_{mech} (max. rotary speed n_{mech})
- ▶ Max. permissible drive torque M_{mech}

Determination of the values for the individual mechanical components in the drive train, based on the motor shaft as reference point.

Frictional torque M_R

For motor attachment via motor mount and coupling

$$M_R = M_{Rs}$$

For motor attachment via timing belt side drive

$$M_R = M_{Rsd} + \frac{M_{Rs}}{i}$$

Mass moment of inertia J_{ex}

For motor attachment via motor mount and coupling

$$J_{ex} = J_s + J_t + J_c$$

For motor attachment via timing belt side drive

$$J_{ex} = J_{sd} + \frac{(J_s + J_t)}{i^2}$$

Mass moment of inertia for linear motion system components

$$J_s = (k_{j \text{ fix}} + k_{j \text{ var}} \cdot L) \cdot 10^{-6}$$

Determination of the translatory mass moment of inertia for external load

$$J_t = m_{ex} \cdot k_{j \text{ m}} \cdot 10^{-6}$$

Max. permissible travel speed v_{mech}

The lowest of all the values for max. permissible speed of all mechanical components contained in the drive train determines the maximum permissible speed of the mechanical system which has to be taken into consideration as the upper limit for the drive when dimensioning the motor.

Maximum permissible speed

Maximum permissible rotary speed

For motor attachment via motor mount and coupling

For motor attachment via timing belt side drive

Max. permissible drive torque M_{mech}

The lowest (minimum) of all the values for permissible drive torque of all mechanical components contained in the drive train determines the maximum permissible

For motor attachment via motor mount and coupling

For motor attachment via timing belt side drive

Note

When considering the complete drive train (mechanical system and motor/controller), the maximum torque of the motor can lie below the maximum value for the mechanical system (M_{mech}) and thus limit the maximum permissible drive torque of the overall drive train.

If the maximum torque of the motor lies above the upper limit for the mechanical system (M_{mech}), the maximum motor torque must be limited to the permitted value for the mechanical system.

Because it is a system in itself, a linear motion system with ball screw drive will always have a maximum permissible or rotary speed that is lower than the maximum values for the other components in the mechanical system, such as coupling or timing belt side drive, and therefore determines the max. permissible speed of the overall mechanical system.

$$v_{\text{mech}} = v_{\text{max}}$$

$$n_{\text{mech}} = \frac{v_{\text{mech}} \cdot 1\,000 \cdot 60}{P}$$

$$n_{\text{mech}} = \frac{v_{\text{mech}} \cdot i \cdot 1\,000 \cdot 60}{P}$$

drive torque of the mechanical system which has to be taken into consideration as the upper limit for the drive when dimensioning the motor.

$$M_{\text{mech}} = \text{Minimum} (M_{\text{cn}}; M_{\text{p}})$$

$$M_{\text{mech}} = \text{Minimum} (M_{\text{sd}}; \frac{M_{\text{p}}}{i})$$

i	= gear ratio of timing belt side drive	(-)
J_{c}	= mass moment of inertia of the coupling	(kgm ²)
J^{ex}	= mass moment of inertia of mechanical system	(kgm ²)
J^{s}	= mass moment of inertia of the linear motion system	(kgm ²)
J_{sd}	= mass moment of inertia of timing belt side drive at motor journal	(kgm ²)
J_{t}	= translatory mass moment of inertia of external load based on the linear motion system screw journal	(kgm ²)
$k_{\text{j fix}}$	= constant for fixed-length portion of mass moment of inertia	(-)
$k_{\text{j m}}$	= constant for mass-specific portion of mass moment of inertia	(-)
$k_{\text{j var}}$	= constant for variable-length portion of mass moment of inertia	(-)
L	= length of linear motion system	(mm)
m_{ex}	= moved external load	(kg)
M_{R}	= frictional torque at motor journal	(Nm)
M_{RS}	= frictional torque of system	(Nm)
M_{Rsd}	= frictional torque of timing belt side drive at motor journal	(Nm)

Drive dimensioning

Drive dimensioning

Rough guide for motor selection

The following conditions can be used as a rough guide for preselecting the motor.

Condition 1:

The rotational speed of the motor must be the same as or higher than the speed required for the mechanical system (but not exceeding the maximum permissible value):

$$n_{\max} \geq n_{\text{mech}}$$

Condition 2:

Consideration of the ratio of mass moments of inertia of the mechanical system and the motor. The mass moments of inertia ratio serves as an indicator for the control performance of a motor/controller combination. The mass moment of inertia of the motor is directly related to the motor size.

Mass moment of inertia ratio

For preselection, experience has shown that the following ratios will result in high control performance. These are not rigid limits, but values exceeding them will require closer consideration of the specific application.

$$V = \frac{J_{\text{ex}}}{J_m + J_{\text{br}}}$$

Application area	V
Handling	≤ 6.0
Processing	≤ 1.5

i	= gear ratio of timing belt side drive	(–)
J _{br}	= mass moment of inertia of the motor brake	(kgm ²)
J _{ex}	= mass moment of inertia of mechanical system	(kgm ²)
J _m	= mass moment of inertia of the motor	(kgm ²)
M _p	= maximum permissible drive torque of the linear motion system	(Nm)
M _{cN}	= rated torque of coupling	(Nm)
M _{sd}	= maximum permissible drive torque of the timing belt side drive	(Nm)
M _{mech}	= maximum permissible drive torque for mechanical system	(Nm)
n _{max}	= maximum speed of the motor	(rpm)
n _{mech}	= maximum permissible rotary speed of mechanical system	(rpm)
P	= screw lead	(mm)
v _{max}	= maximum permissible speed of linear motion system	(m/s)
V	= ratio of mass moments of inertia of drive train and motor	(–)
v _{mech}	= maximum permissible speed of mechanical system	(m/s)

Condition 3:

Estimation of the ratio of the static load moment to the continuous torque of the motor. The torque ratio must be smaller than or equal to the empirical value of 0.6. By looking at the required motor torque levels, this estimation

Torque ratio:**Static load moment:****Weight moment:**

For vertical mounting only.
For motor attachment via motor mount and coupling: $i = 1$

In the section “Configuration and Ordering” users can put together standard configurations, including motor attachment and motor, for the various linear motion system sizes by selecting the appropriate options.

By checking the above conditions it is possible to see whether a standard motor selected in a particular configuration will generally be of a suitable size for the specific application.

Precise dimensioning of the drive

Preselecting the motor according to this rough guide is no substitute for the required precise design calculations for the drive, taking all moments/torques and speed levels into account. For precise calculation of the electric drive, including consideration of the specific motion profile, please refer to the performance data in the catalogs “IndraDrive Cs” and “IndraDrive C”.

When dimensioning the drive, the maximum permissible values for linear speed, drive torque and acceleration must not be exceeded, in order to avoid damaging the mechanical system.

roughly covers the dynamic characteristics which still have to be determined by plotting an exact motion profile.

$$\frac{M_{\text{stat}}}{M_0} \leq 0.6$$

$$M_{\text{stat}} = M_R + M_g$$

$$M_g = \frac{P \cdot (m_{\text{ex}} + m_{\text{ca}}) \cdot g}{2\,000 \cdot \pi \cdot i}$$

g	= force of gravity (= 9.81)	(m/s ²)
i	= gear ratio of timing belt side drive	(–)
m_{ca}	= moved mass of carriage	(kg)
m_{ex}	= moved external load	(kg)
M_g	= weight moment at motor journal	(Nm)
M_0	= continuous motor torque	(Nm)
M_R	= frictional torque at motor journal	(Nm)
M_{stat}	= static longitudinal moment load	(Nm)
P	= screw lead	(mm)
π	= pi	(–)

Drive dimensioning

Given data:

In a handling task, a mass (m_{ex}) of 15 kg is to be moved vertically by 300 mm at a travel speed of 0.5 m/s. The following was selected based on the technical data and the installation space:

Feed module VKK-070:

- ▶ with adapter flange
- ▶ without bellows cover
- ▶ motor attachment via timing belt side drive, $i = 1.5$
- ▶ with servo motor MSM 031C with brake

1 External load (m_{ex})

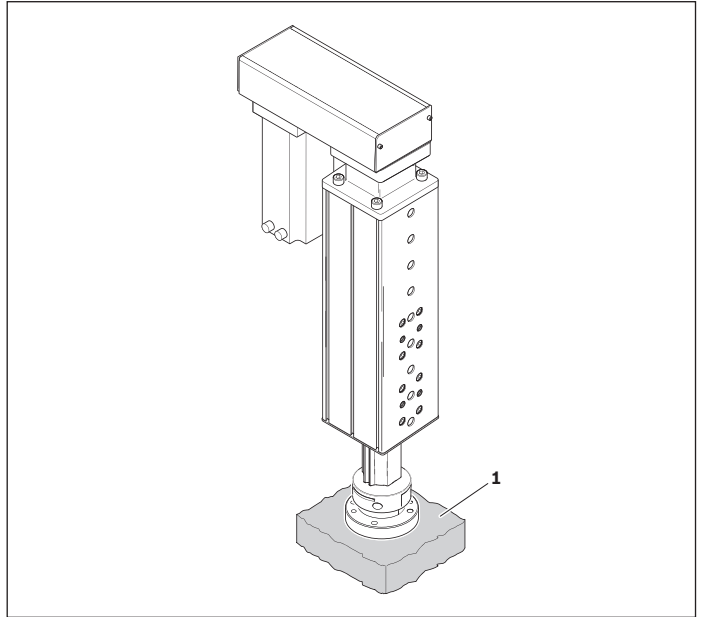

Selection of the ball screw drive:

(Always choose the lowest lead as this is favorable in terms of resolution, braking distance, length)

Permitted ball screw drives according to “Max. permissible travel speed” graph

at $v = 0.5$ m/s:

BASA 16 x 10 and BASA 16 x 16

Selected ball screw drive (lower lead):

BASA 16 x 10

Maximum permissible speed for BASA 16 x 10 from graph:

$v_{max} = 0.77$ m/s

Calculation of slide length L

(for selected BASA)

Excess travel (per side): $s_e = 2 \cdot P = 2 \cdot 10 = 20$ mm

Max. travel: $s_{max} = s_{eff} + 2 \cdot s_e = 300 + 2 \cdot 20 = 340$ mm

Next longest available max. travel from table: $s_{max} = 374$ mm

Corresponding length from table: $L = 520$ mm

Frictional torque M_R :

(motor attachment via timing belt side drive)

$$M_R = M_{Rsd} + \frac{M_{RS}}{i}$$

VKK: $M_{RS} = 0.34$ Nm

Timing belt side drive: $M_{Rsd} = 0.35$ Nm

Frictional torque: $M_R = 0.35 + \frac{0.34}{1.5} = 0.57$ Nm

Mass moment of inertia J_{ex}

For motor attachment via timing belt side drive

$$J_{ex} = J_{sd} + \frac{(J_s + J_t)}{i^2}$$

Timing belt side drive excess travel	$J_{ex} = 13.3 \cdot 10^{-6} \text{ kgm}^2$
VKK	$J_s = (k_{J \text{ fix}} + k_{J \text{ var}} \cdot L) \cdot 10^{-6} = (4.35 + 0.039 \cdot 520) \cdot 10^{-6} = 24.63 \cdot 10^{-6} \text{ kgm}^2$
External load	$J_t = m_{ex} \cdot k_{J \text{ m}} \cdot 10^{-6} = 15 \cdot 2.533 \cdot 10^{-6} = 37.995 \cdot 10^{-6} \text{ kgm}^2$
Moment of inertia	$J_{ex} = 13.3 \cdot 10^{-6} + = \frac{(24.63 \cdot 10^{-6} + 37.995 \cdot 10^{-6})}{1.52} = 41.133 \cdot 10^{-6} \text{ kgm}^2$

Maximum permissible rotary speed n_{mech} :

For motor attachment via timing belt side drive

$$n_{mech} = \frac{v_{mech} \cdot i \cdot 1\,000 \cdot 60}{P}$$

Max. permissible travel speed:	$v_{mech} = v_{max} = 0.77 \text{ m/s}$
Max. permissible rotary speed:	$n_{mech} = \frac{(0.77 \cdot 1.5 \cdot 1\,000 \cdot 60)}{10} = 6\,930 \text{ rpm}$

Rotary speed of application n_{mech} :

For motor attachment via timing belt side drive

Travel speed:	$v_{mech} = 0.5 \text{ m/s}$
Rotary speed:	$n_{mech} = \frac{(0.5 \cdot 1.5 \cdot 1\,000 \cdot 60)}{10} = 4\,500 \text{ rpm}$

Max. permissible drive torque M_{mech}

For motor attachment via timing belt side drive with limit for mechanical system

$$M_{mech} = \text{minimum} \left(M_{sd}; \frac{M_p}{i} \right)$$

Timing belt side drive:	$M_{sd} = 2.11 \text{ Nm}$ (gear ratio $i = 1.5$ for MSM 031C)
VKK:	$M_p = 6.1 \text{ Nm}$
Drive torque:	$M_{mech} = \text{minimum} \left(2.11; \frac{6.1}{1.5} \right) = \text{minimum} (2.11; 4.06) = 2.11 \text{ Nm}$

Calculation example

Calculation example for drive dimensioning

Checking the motor preselection:

Selected motor: MSM 031C with brake

Condition 1:

$$n_{\max} \geq n_{\text{mech}}$$

5 000 \geq 4 500; Condition met – motor size OK

Condition 2

Mass moment of inertia ratio:
$$V = \frac{J_{\text{ex}}}{J_{\text{m}} + J_{\text{br}}}$$

Motor inertia:
$$J_{\text{m}} = 26 \cdot 10^{-6} \text{ kgm}^2$$

Brake moment of inertia:
$$J_{\text{br}} = 1.8 \cdot 10^{-6} \text{ kgm}^2$$

Moment of inertia ratio:
$$V = \frac{41.133 \cdot 10^{-6}}{(26 \cdot 10^{-6} + 1.8 \cdot 10^{-6})} = 1.48$$

Condition for handling: $V \leq 6$; $1.48 \leq 6$; Condition met – motor size OK

Condition 3

Torque ratio:
$$M_{\text{stat}} / M_0 \leq 0.6$$

Static load moment:
$$M_{\text{stat}} = M_{\text{R}} + M_{\text{g}}$$

Weight moment:
$$M_{\text{g}} = P \cdot (m_{\text{ex}} + m_{\text{ca}}) \cdot g / 2\,000 \cdot \pi \cdot i = 10 \cdot (15 + 1.51) \cdot 9.81 / 2\,000 \cdot \pi \cdot 1.5 = 0.17 \text{ Nm}$$

Static load moment:
$$M_{\text{stat}} = 0.57 + 0.17 = 0.74 \text{ Nm}$$

Continuous motor torque:
$$M_0 = 1.3 \text{ Nm}$$

Torque ratio: $0.74 / 1.3 = 0.57$, $0.57 \leq 0.6$; Condition met – motor size OK

Result

Feed module:	VKK-070
Length:	L = 520 mm
Max. travel:	s _{max} = 374 mm with adapter flange BASA 16 x 10 without bellows cover motor attachment via timing belt side drive, gear ratio i = 1.5
Preselected motor:	MSM 031C with brake

For precise dimensioning of the electric drive, the motor-controller combination must always be considered, as the performance data (e.g. maximum useful speed and maximum torque) will depend on the controller used.

When doing this, the following data must be considered.

Frictional torque:	M _R	= 0.57 Nm
Mass moment of inertia:	J _{ex}	= 41.133 · 10 ⁻⁶ kgm ²
Travel speed:	v _{mech}	= 0.5 m/s (n _{mech} = 4 500 rpm)
Limit for drive torque:	M _{mech}	= 2.11 Nm
=> The motor torque must be limited to 2.11 Nm on the drive side!		
Acceleration limit:	a _{max}	= 27 m/s ²
Limit for travel speed:	v _{mech}	= 0.77 m/s (n _{mech} = 6 930 rpm)

Besides the preferred type MSM 031C, other motors with identical connection dimension can be adapted while taking care not to exceed the calculated limits.

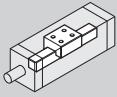
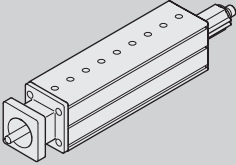
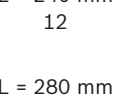
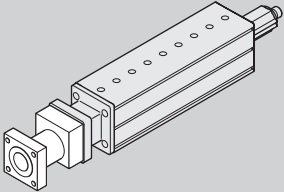
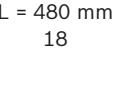
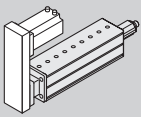
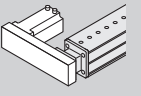
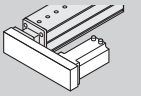

VKK-050

Configuration and ordering

Short product name, length VKK-050-NN-1, mm		Guideway	Drive			Carriage						
			Screw journal	BASA size d ₀ x P		without adapter flange	with adapter flange					
				12x2	12x5			12x10				
with BASA, without motor mount	OF01	OF01		Ø 6	01	02	03	03	04			
												
with BASA and motor mount	MF01	MF01		Ø 6	L = 240 mm 12	01	02	03	03	04		
					L = 280 mm 13							
					L = 360 mm 15							
with BASA and timing belt side drive	RV01 ¹⁾	RV01 to RV04		Ø 6	L = 480 mm 18	01	02	03	03	04		
												
	RV03											
	RV04											

Ordering example: See "Inquiry/Order Form"

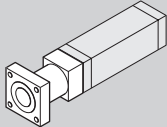
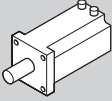
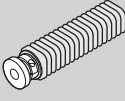
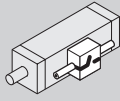
BASA = ball screw drive
d₀ = nominal diameter (mm)
P = lead (mm)

Motor attachment			Motor		Cover		Switching system		Documentation		
											
Gear ratio $i =$	Attachment kit ²⁾	for motor	without	with	without	with			Standard report	Measurement report ⁵⁾	
			brake		bellows						
	00	–	00								
1	04	MSM 019B	134	135	00	01 ³⁾	Without switch 00		01	02	
	02	MSK 030C	84	85			Magnetic field sensor:				03
	03	MSM 031B	136	137			– Reed sensor	21			
				– Hall sensor (PNP NC)			22				
				Magnetic field sensor with connector:				05			
				– Reed sensor			58				
				– Hall sensor (PNP NC)	59						
1	27	MSM 019B	134	135							
1.5	28										
1	23	MSM 031B	136	137							
1.5	24										
1	21	MSK 030C	84	85							
1.5	22										

Switch mounting arrangements

Refer to “Switch mounting arrangements” for more information on switch types and switch mounting.

- 1) Consider the position of the lube ports! Please refer to the “Lubrication” section.
- 2) Attachment kit also available without motor (when ordering: enter “00” for motor)
- 3) Can only be selected in combination with adapter flange (carriage option 04)
- 4) “02” = Frictional torque measurement,
“03” = Lead deviation:
“05” = Positioning accuracy (see section “Documentation”)

VKK-050

Dimension drawings

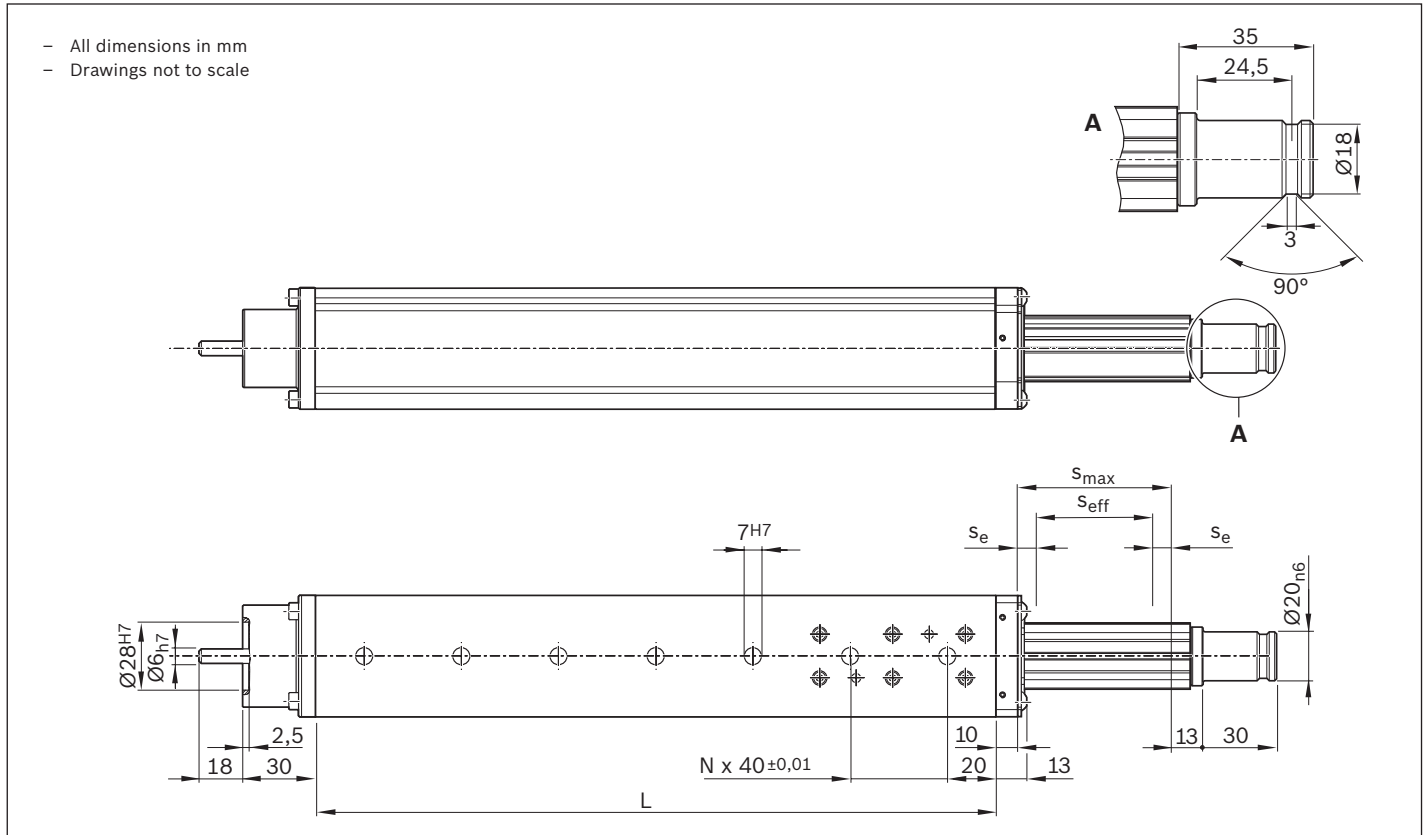

L (mm)	s _{max} ¹⁾	
	without bellows (mm)	with bellows (mm)
240	138	97
280	178	131
360	258	199
480	378	301

1) Consider excess travel!

s_e = excess travel
s_{eff} = effective stroke
s_{max} = maximum travel

$$s_{eff} = s_{max} - s_e$$

Maximum travel = effective stroke + 2 · excess travel
For safe operation the excess travel must be longer than the braking distance.

In most cases the general guideline value for excess travel (braking distance) is:

Excess travel = 2 · screw lead P
Example: BASA 12 x 5 (d₀ x P)

▼ Option with adapter flange

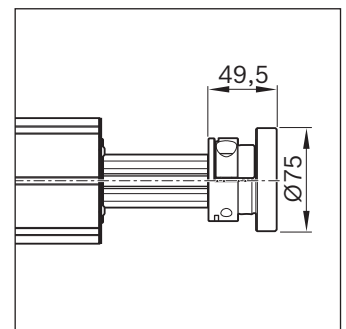

See section "Connection elements" for more information.

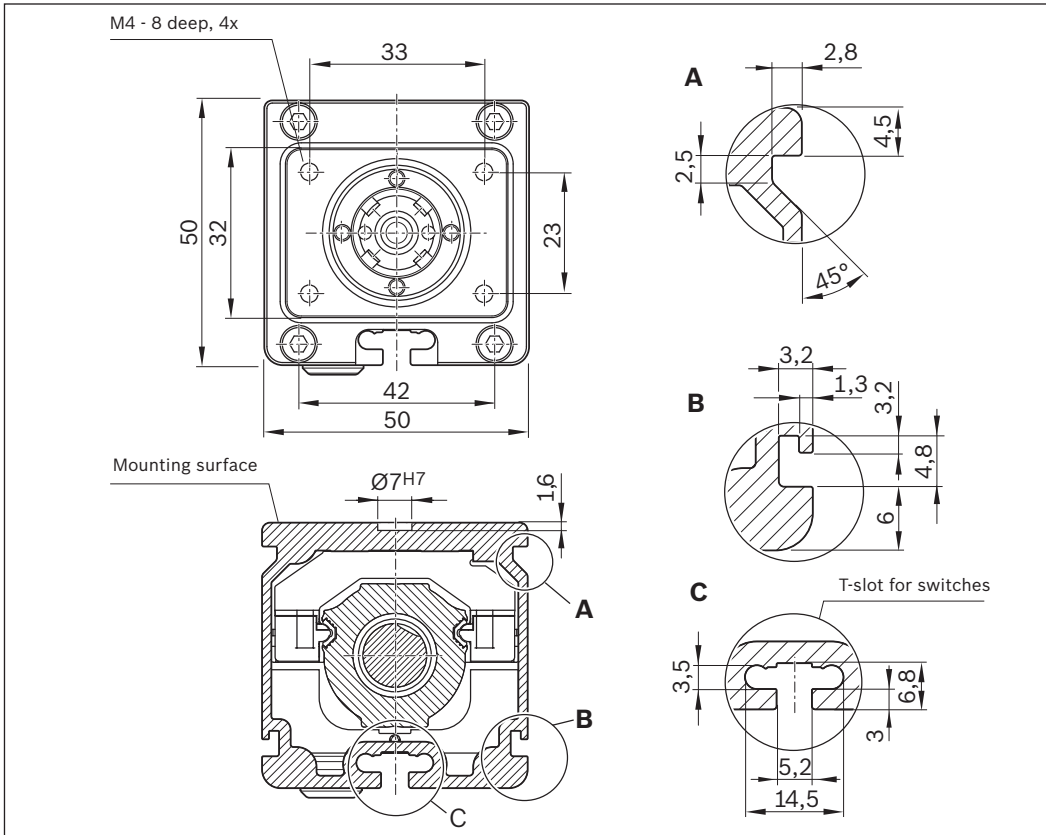

Version	Motor	Dimensions (mm)											
		D	E		F	G	G ₁	K	L _f	without brake	L _m with brake	L _{sd}	
			i = 1	i = 1.5								i = 1	i = 1.5
RV01 to RV04	MSM 019B	42	76.5	76.5	48.0	27	29.0	27.5	-	92	122.0	139	139
	MSM 031B	60	78.0	75.0	64.5	37	43.5	33.5	-	79	115.5	157	157
	MSK 030C	54	78.0	75.0	64.5	37	43.5	33.5	-	188	213.0	154	154
MF01	MSM 019B	42	-	-	-	-	-	-	44	92	122.0	-	-
	MSM 031B	60	-	-	-	-	-	-	50	79	115.5	-	-
	MSK 030C	54	-	-	-	-	-	-	50	188	213.0	-	-

▼ Type OF01

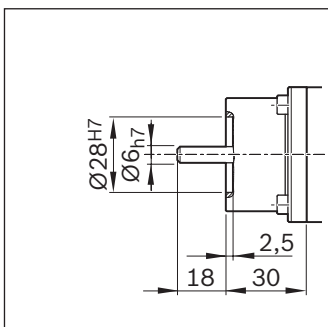

▼ Type MF01

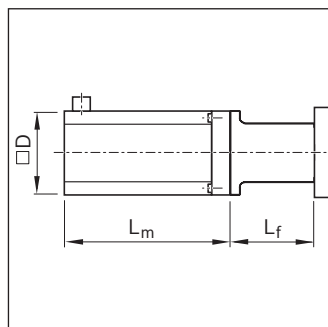

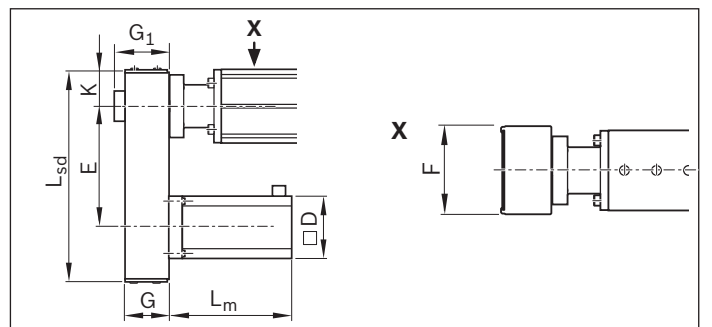

▼ Type RV01, RV02, RV03, RV04



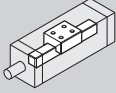
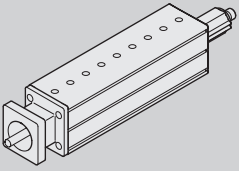
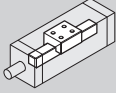
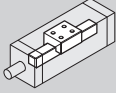
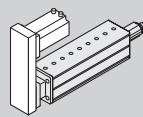
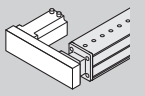
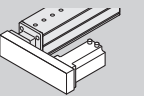

VKK-070

Configuration and ordering

Short product name, length VKK-070-NN-1, mm		Guideway	Drive			Carriage				
			Screw journal	BASA size d ₀ x P			without adapter flange	with adapter flange		
				16x5	16x10	16x16				
with BASA, without motor mount	OF01	OF01		Ø 9	01	02	03	03	04	
				Ø 9 key-way	11	12	13			
with BASA and motor mount	MF01	MF01		L = 280 mm 12	Ø 9	01	02	03	03	04
				L = 320 mm 13						
				L = 400 mm 15						
				L = 520 mm 18						
with BASA and timing belt side drive	RV01 ¹⁾	RV01 to RV04		L = 600 mm 20	Ø 9	01	02	03	03	04
	RV02									
	RV03									
	RV04									

Ordering example: See “Inquiry/Order Form”

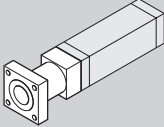
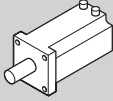
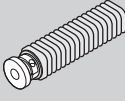
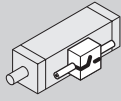
BASA = ball screw drive
d₀ = nominal diameter (mm)
P = lead (mm)

Motor attachment		Motor		Cover		Switching system		Documentation		
										
Gear ratio $i =$	Attachment kit ²⁾	For motor	without with brake	without with bellows				Standard report	Measurement report ⁵⁾	
	00	-	00							
1	01	MSM 031C	138	139	00	01 ³⁾	without switch	00	02	
	02	MSK 030C	84	85			Magnetic field sensor:			
	03	MSM 041B	140	141			- Reed sensor	21		03
	04	MSM 040C	116	117			- Hall sensor (PNP NC)	22		
1	33	MSM 031C	138	139	00	01 ³⁾	Magnetic field sensor with connector:			
	34						- Reed sensor	58		05
1.5	31	MSK 030C	84	85	00	01 ³⁾	- Hall sensor (PNP NC)	59		
1	32									
1.5	37	MSM 041B	140	141	00	01 ³⁾				
1	38									
1.5	35	MSK 040C	86	87	00	01 ³⁾				
1	36									

Switch mounting arrangements

Refer to “Switch mounting arrangements” for more information on switch types and switch mounting.

- 1) Consider the position of the lube ports! Please refer to the “Lubrication” section.
- 2) Attachment kit also available without motor (when ordering: enter “00” for motor)
- 3) Can only be selected in combination with adapter flange (carriage option 04)
- 4) “02” = Frictional torque measurement,
“03” = Lead deviation:
“05” = Positioning accuracy (see section “Documentation”)

VKK-070

Dimension drawings

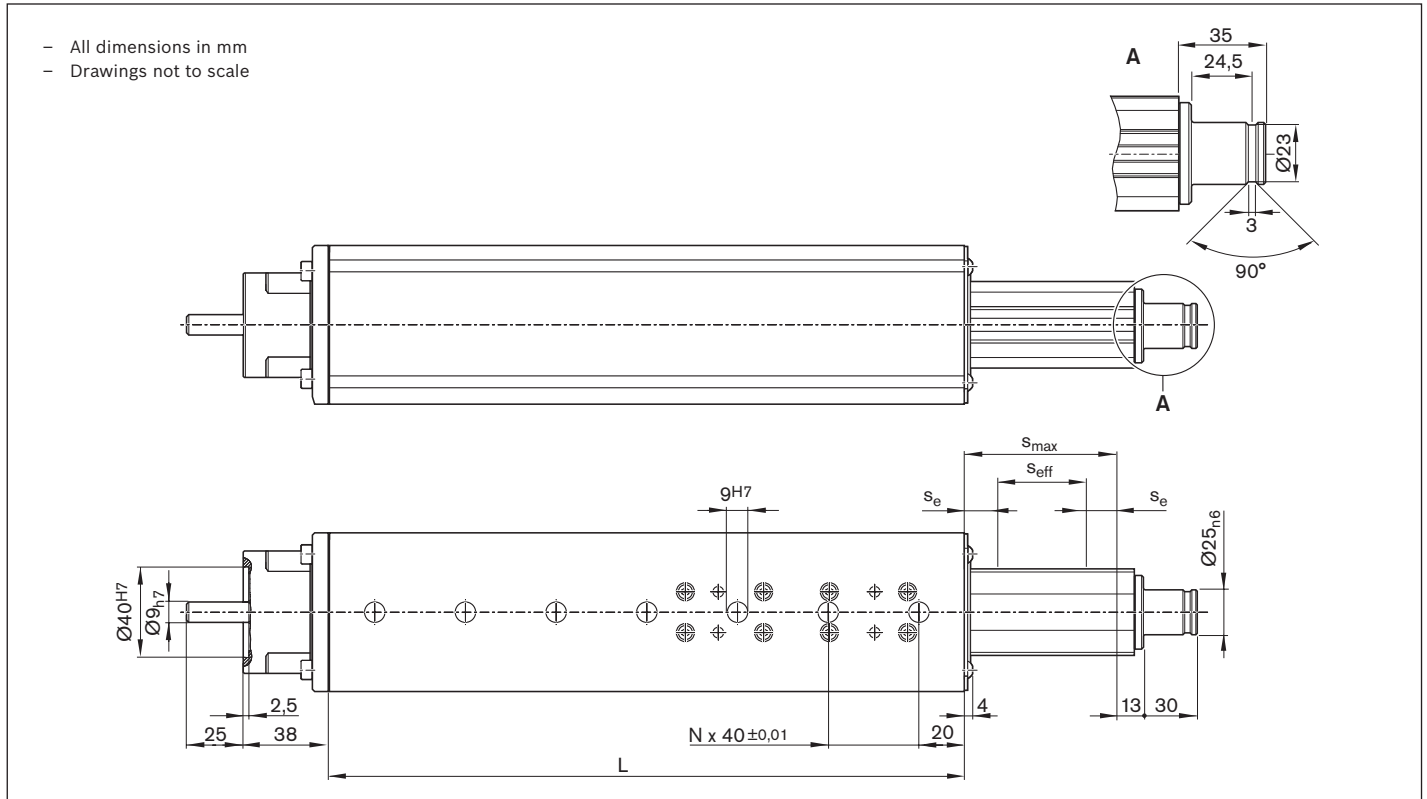

L (mm)	s _{max} ¹⁾	
	without bellows (mm)	with bellows (mm)
280	132	95
320	172	129
400	252	197
520	372	299
600	452	367

1) Consider excess travel!

s_e = excess travel
s_{eff} = effective stroke
s_{max} = maximum travel

$$s_{eff} = s_{max} - s_e$$

Maximum travel = effective stroke + 2 · excess travel
For safe operation the excess travel must be longer than the braking distance.

In most cases the general guideline value for excess travel (braking distance) is:

Excess travel = 2 · screw lead P

Example: BASA 12 x 5 (d₀ x P)

▼ Option with adapter flange

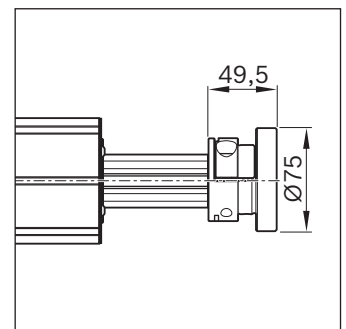

See section "Connection elements" for more information.

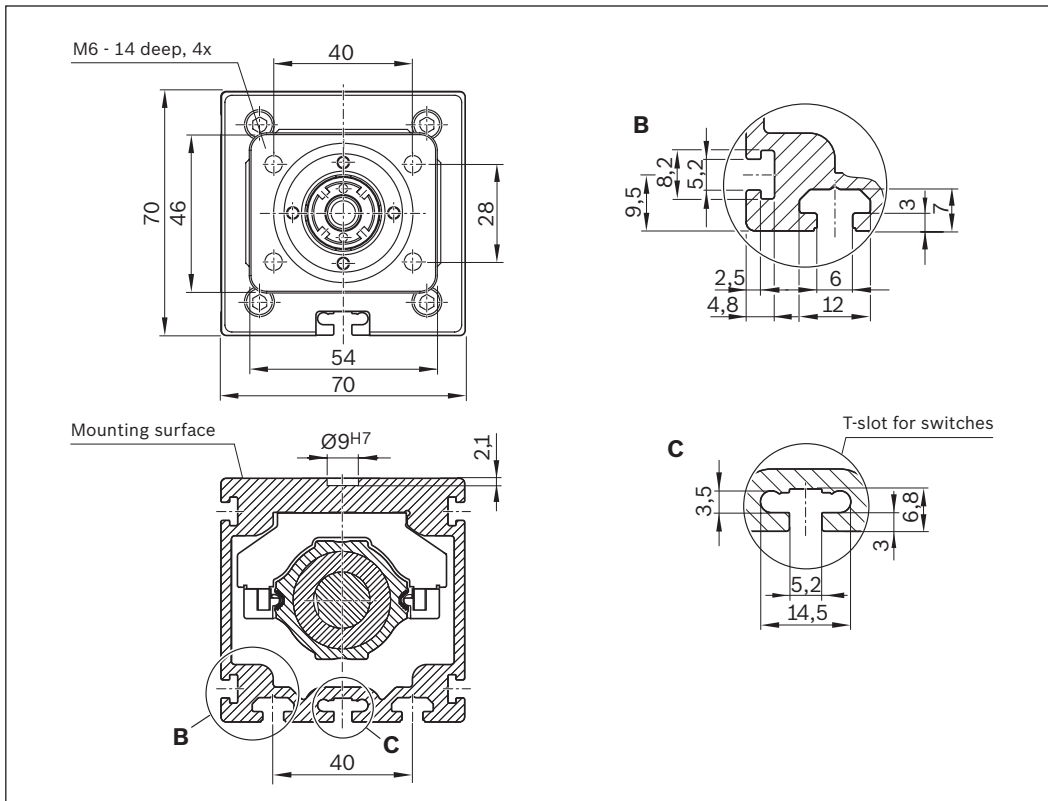

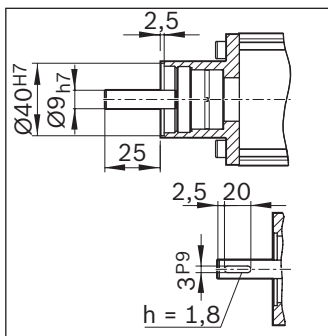
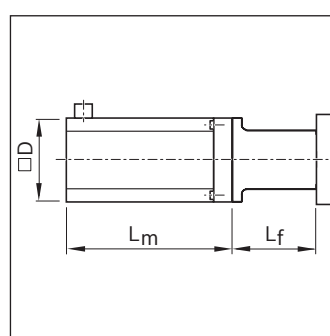
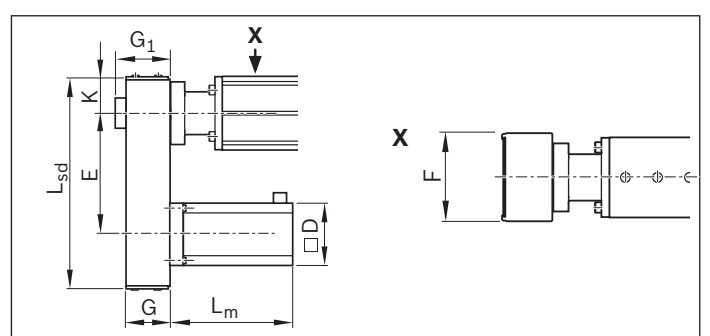

Version	Motor	Dimensions (mm)										L _m		L _{sd}	
		D	E		F	G	G ₁	K	L _f	without	with	i = 1	i = 1.5		
			brake	brake											
RV01 to RV04	MSM 031C	60	103.5	115	64.5	37	43.5	33.5	-	98.5	135.0	179	191		
	MSM 041B	80	122.0	122	88.0	51	57.0	45.5	-	112.0	149.0	220	220		
	MSK 030C	54	103.5	115	64.5	37	43.5	33.5	-	188.0	213.0	179	191		
	MSK 040C	82	122.0	122	88.0	51	57.0	45.5	-	185.5	215.5	220	220		
MF01	MSM 031C	60	-	-	-	-	-	-	72.0	98.5	135.0	-	-		
	MSM 041B	80	-	-	-	-	-	-	83.0	112.0	149.0	-	-		
	MSK 030C	54	-	-	-	-	-	-	75.5	188.0	213.0	-	-		
	MSK 040C	82	-	-	-	-	-	-	77.5	185.5	215.5	-	-		

▼ Type OF01

▼ Type MF01

▼ Type RV01, RV02, RV03, RV04

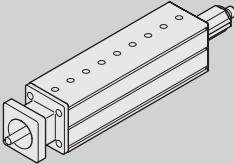
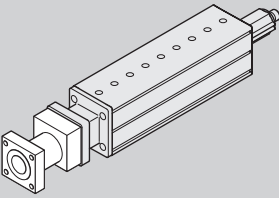
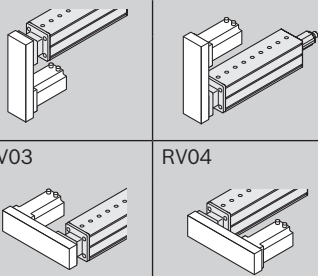

VKK-100

Configuration and ordering

Short product name, length VKK-100-NN-1, mm		Guideway	Drive			Carriage		Version		
			Screw journal	BASA size d ₀ x P		without adapter flange	with adapter flange			
				20x5	25x10	20x20				
With BASA, without motor mount	OF01		OF01	Ø 14	01	02	03	03	04	
				Ø 14 key-way	11	12	13			
with BASA and motor mount	MF01		MF01	L = 360 mm 12	Ø 14	01	02	03	03	04
				L = 400 mm 13						
				L = 480 mm 15						
				L = 600 mm 18						
with BASA and timing belt side drive	RV01 ¹⁾		RV01 to RV04	L = 680 mm 20	Ø 14	01	02	03	03	04
	RV02									
	RV03									
	RV04									

Ordering example: See "Inquiry/Order Form"

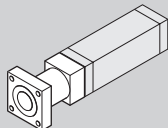
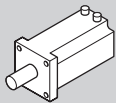
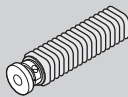
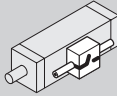
BASA = ball screw drive
 d₀ = nominal diameter (mm)
 P = lead (mm)

Motor attachment			Motor		Cover		Switching system		Documentation	
										
Gear ratio i =	Attachment kit ²⁾	for motor	without brake	with brake	without bellows	with bellows			Standard report	Measurement report ⁵⁾
	00	-	00							
1	03	MSM 041B	140	141	00	01 ³⁾	without switch 00		01	02
	05	MSK 050C	88	89			Magnetic field sensor:			
- Reed sensor					21					
							Magnetic field sensor with connector:			
							- Reed sensor	58		03
							- Hall sensor (PNP NC)	59		05
1	27	MSM 041B	140	141	00	01 ³⁾			01	
1.5	28									
1	29	MSK 050C	88	89	00	01 ³⁾			01	
1.5	30									

Switch mounting arrangements

Refer to “Switch mounting arrangements” for more information on switch types and switch mounting.

- 1) Consider the position of the lube ports! Please refer to the “Lubrication” section.
- 2) Attachment kit also available without motor (when ordering: enter “00” for motor)
- 3) Can only be selected in combination with adapter flange (carriage option 04)
- 4) “02” = Frictional torque measurement, “03” = Lead deviation: “05” = Positioning accuracy (see section “Documentation”)

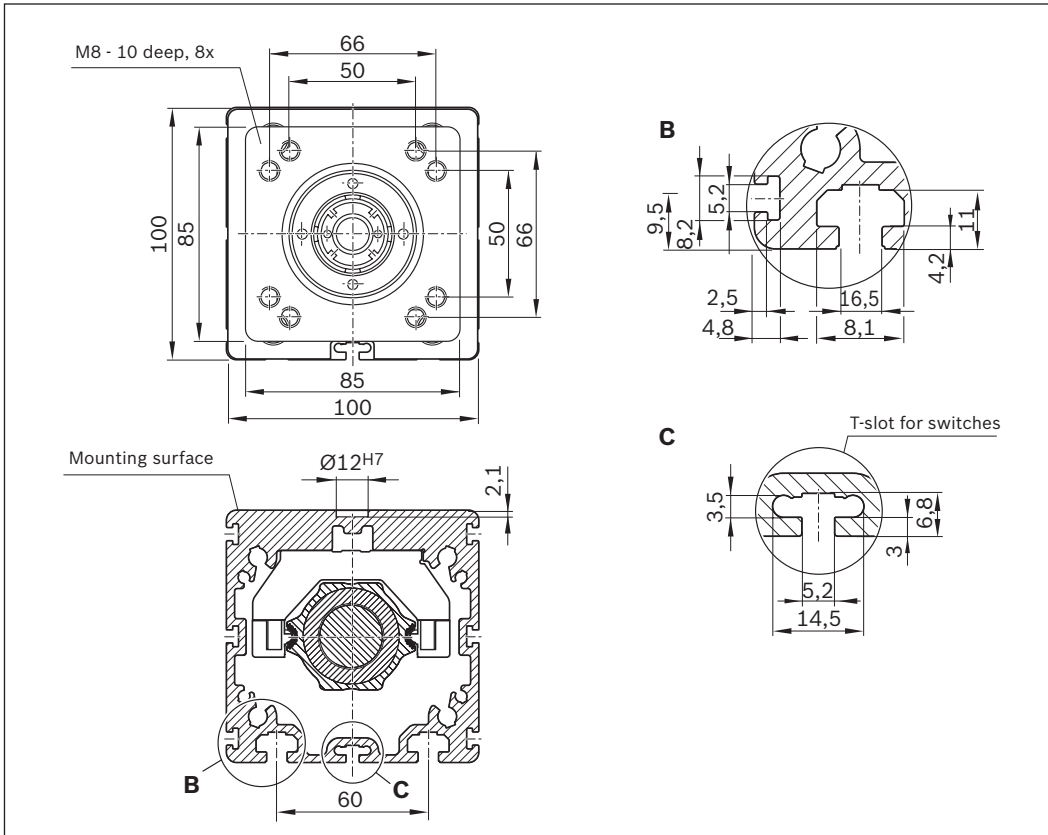

Version	Motor	Dimensions (mm)								L _f	without brake	L _m with brake	L _{sd}		
		D	i = 1	i = 1.5	i = 2	E	F	G	K				i = 1	i = 1.5	i = 2
RV01 to RV04	MSM 041B	80	122	122	-	88	51	45.5	-	112	149	231	231	-	
	MSK 050C	98	154	-	154	116	66	57.0	-	203	233	280	-	280	
MF01	MSM 041B	80	-	-	-	-	-	-	90	112	149	-	-	-	
	MSK 050C	98	-	-	-	-	-	-	115	203	233	-	-	-	

▼ Type OF01

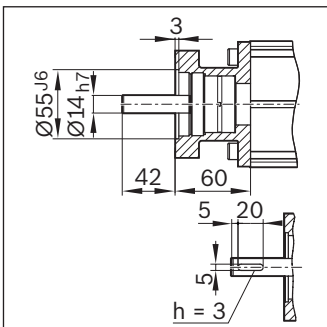

▼ Type MF01

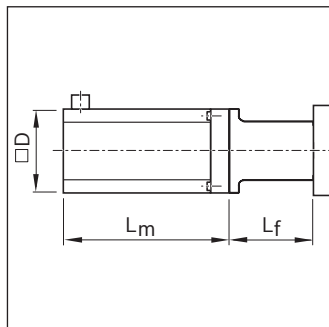

▼ Type RV01, RV02, RV03, RV04

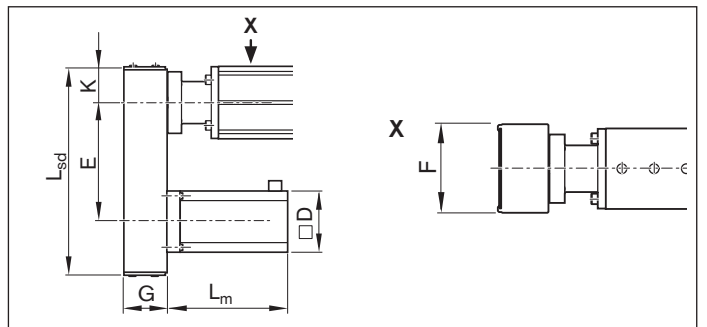

Mounting

Fastening with clamping fixtures

The modules are mounted using clamping fixtures which engage in the T-slots on the side of the frame.

Clamping fixtures

Size	Dimensions (mm)	
	A	B
VKK-050	62.5	75.5
VKK-070	86.0	100.0
VKK-100	116.0	130.0

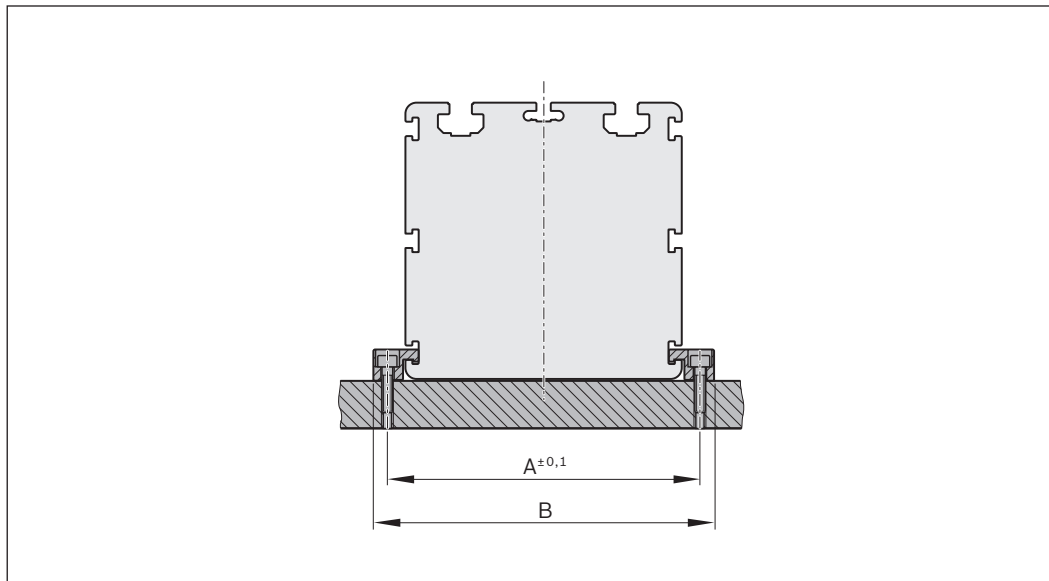

Mounting surface

The Feed Module may only be installed/connected to other modules by the mounting surface with the centering holes.

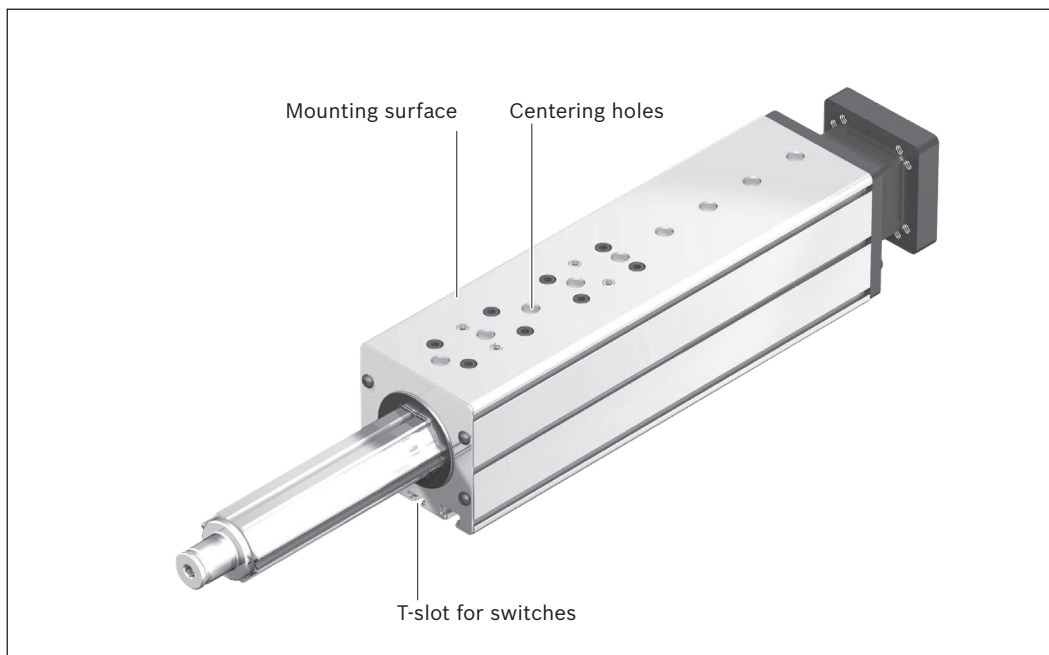

Clamping fixtures

Recommended number of clamping fixtures:

- Type 1: 4 pieces per side/per 300mm
- Type 2: 2 pieces per side/per 300 mm
- Type 3: 1 piece per side/per 300 mm

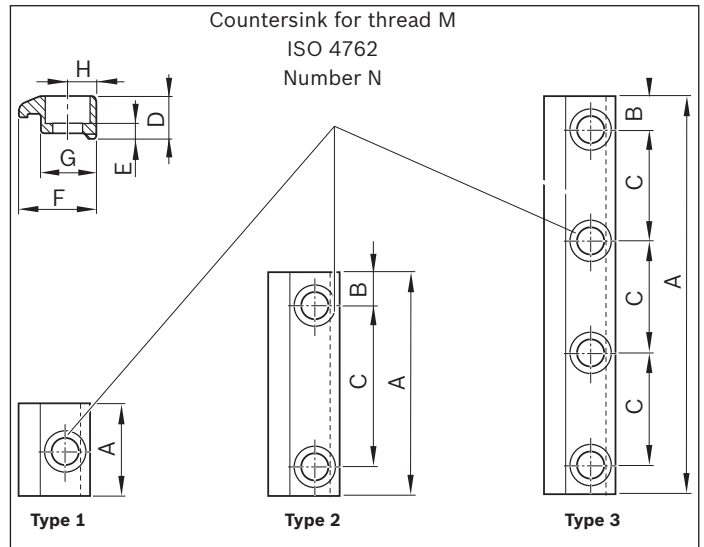

Size	for	Type	Number of bores	Dimensions (mm)									Part number
				N	A	B	C	D	E	F	G	H	
VKK-050	M5	1	1	22	-	-	10.0	4.8	15.1	12.2	6.5	R1419 010 01	
		2	2	57	8.5	40						R1419 010 43	
		3	4	77	8.5	20						R1419 010 44	
VKK-070	M5	3	4	107	8.5	30	11.5	4.8	19.3	14	7.0	R0375 410 02	
		3	4	77	8.5	20						R0375 410 26	
VKK-070 VKK-100	M6	1	1	25	-	-	11.5	5.3	19.3	14	7.0	R0375 510 00	
		3	4	142	11	40						R0375 510 02	
		2	2	72	11	50						R0375 510 33	
		2	2	62	11	40						R0375 510 34	
		2	2	47	8.5	30							R0375 510 23

Mounting to Installed Modules

- ▶ No intermediate plates required
- ▶ Positive lock via centering rings (EasyHandling compatible)
- ▶ Easy mounting with clamping fixtures

See “Connection technology for linear motion systems” catalog for more detailed information

▼ **Feed Module VKK mounted to Compact Module CKK**

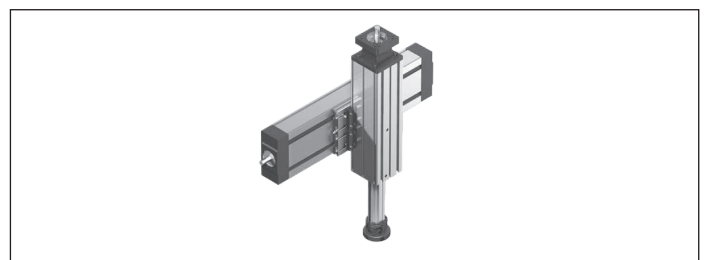

Mounting Accessories

Centering ring

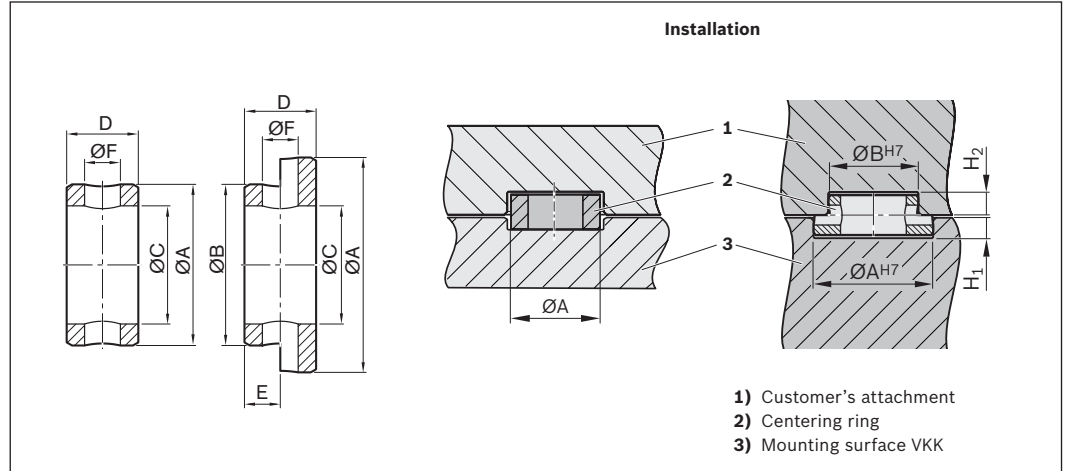

The centering ring serves as a positioning aid and for positive locking when fastening the VKK. It creates a positive-locking connection with good reproducibility. Material: steel (corrosion-resistant).

Ø Size (mm)	Dimensions (mm)								Part number
	A k6	B k6	C ±0.1	D -0.2	E +0.2	ØF	H1 +0.2	H2 +0.2	
7	7	–	5.5	3.0	–	1.6	1.6	–	R0396 605 43
9	9	–	6.6	4.0	–	2.0	2.1	–	R0396 605 44
12	12	–	9.0	4.0	–	2.0	2.1	–	R0396 605 45
7 - 5	7	5	3.4	3.0	1.5	1.6	1.6	1.6	R0396 605 47
9 - 5	9	5	3.4	3.5	1.5	1.6	2.1	1.6	R0396 605 48
9 - 7	9	7	5.5	3.5	1.5	1.6	2.1	1.6	R0396 605 49
12 - 9	12	9	6.6	4.0	2.0	2.0	2.1	2.1	R0396 605 50

Sliding blocks and springs

For mounting attachments using the T-slots

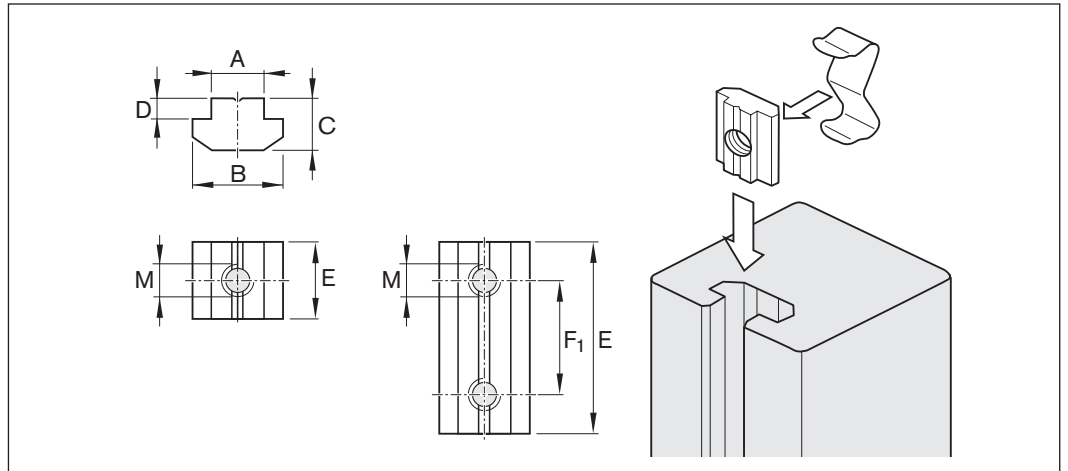

Size	For thread	Dimensions (mm)						Part number		
		A	B	C	D	E	F1	T-nut	Spring	
VKK-050	-	-	-	-	-	-	-	-	-	
VKK-070	M4	6	11.5	4	1	12	-	R3447 014 01	R3412 010 02	
	M4						45	30	R0391 710 09	-
	M5						12	-	R3447 015 01	R3412 010 02
VKK-100	M5	8	16.0	6	2	16	-	R3447 017 01	R3412 010 02	
	M5						16	-	R3447 018 01	R3412 010 02
	M6						16	-	R3447 019 01	R3412 010 02
	M6						50	36	R0391 710 08	-

Connection Elements

Adapter flange

For mounting customer attachments, grippers and rotary compact modules

The assembly kit consists of:

- 1 Adapter flange
- 2 Half shell (for clamping)
- 3 Socket head cap screws (2x ISO 4762)
- 4 Locating pin*)
- 5 Mounting interface
- 6 Groove for locating feature
- 7 Locating feature
- 8 Straight pin with internal thread*)
- 9 Centering rings*)

*)Included in delivery

Note on ordering

The adapter flange can be ordered either by selecting the carriage option 04 (carriage with adapter flange) or by stating the following part numbers.

Size	Adapter flange Part number
VKK-050	R1419 000 35
VKK-070	R1419 000 36
VKK-100	R1419 000 37

Size	(3) ISO4762	12.9	$\varnothing U_{H7}$	$\varnothing d_{m6}$	$\varnothing T$
		(Nm)	(mm)	(mm)	(mm)
VKK-050	M6x25	14	20	3.5	29.0
VKK-070	M8x30	35	25	3.5	38.7
VKK-100	M8x30		25	5.5	51.5

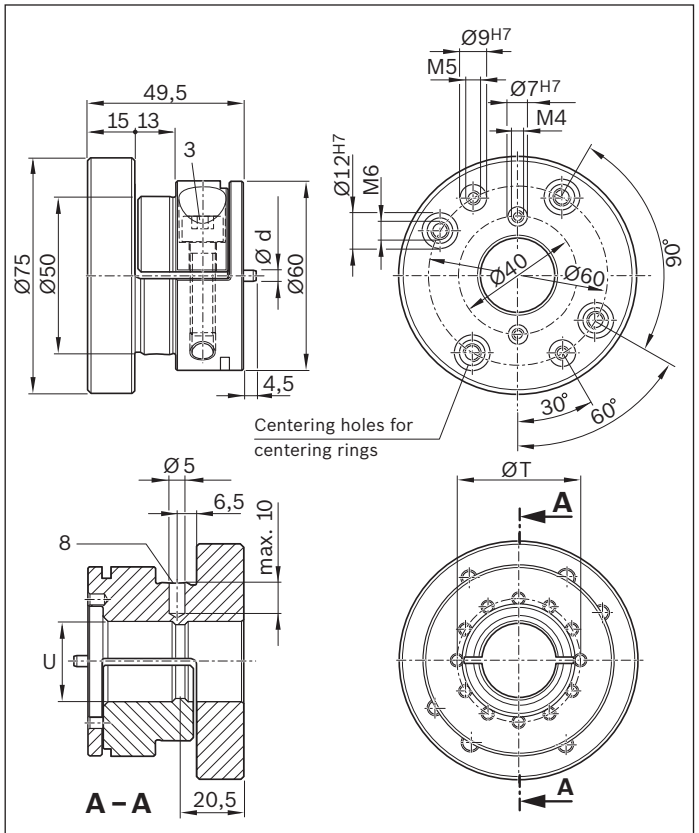
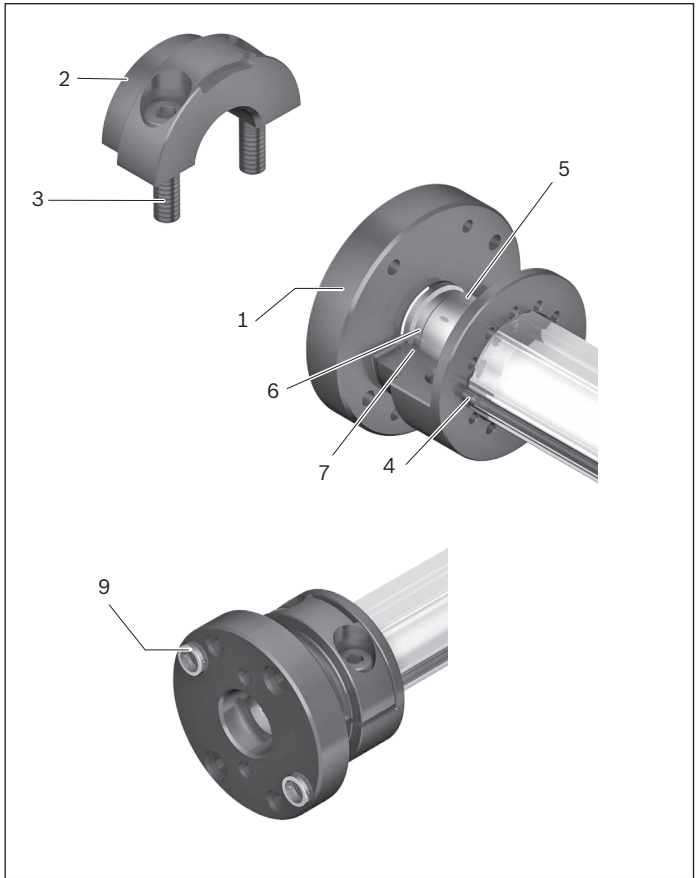

Bellows cover

Protects the thrust rod and guideway from contamination

Sealed polyester fabric bellows coated with polyurethane on two sides, welded version. Oil- and moisture-resistant.

The assembly kit consists of:

- 1 Retaining plate (2x)
- 2 Lower mounting flange
- 3 Polyurethane bellows
- 4 Outside clamping plate (8x)
- 5 Inside clamping plate (2x)
- 6 Upper mounting flange
- 7 Fastening screws (22x)
- 8 Adapter flange

Note on ordering

The bellows can be ordered by selecting the Cover Option 01 and is only available with the adapter flange (Carriage Option 04).

Note for mounting

The adapter flange is required for installing the bellows.

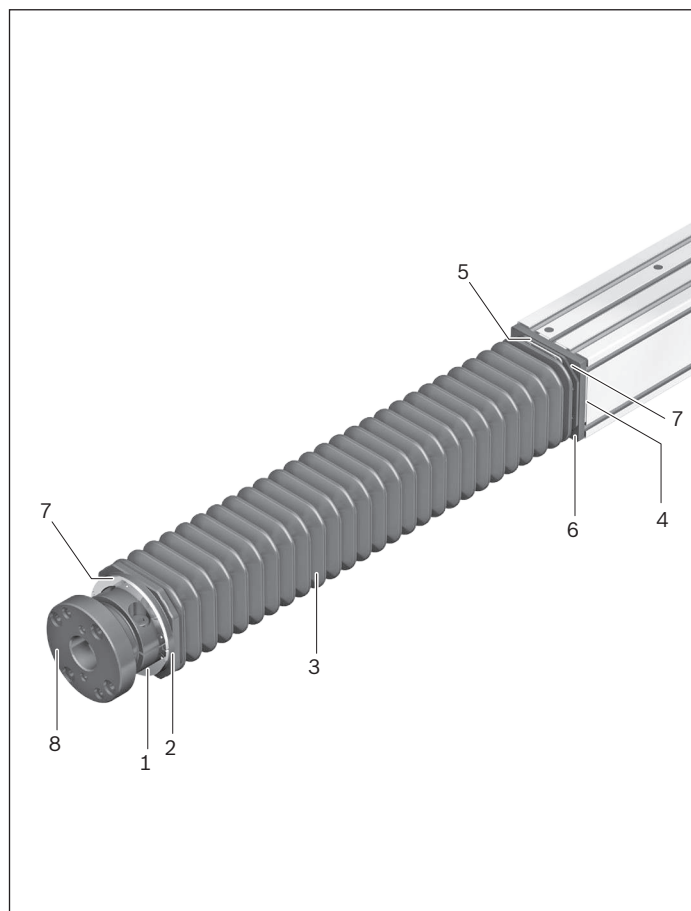

Note

If the bellows cover or adapter flange is removed, the fastening screws must be secured again on re-installation. (For example with liquid medium-strength threadlocking adhesive.)

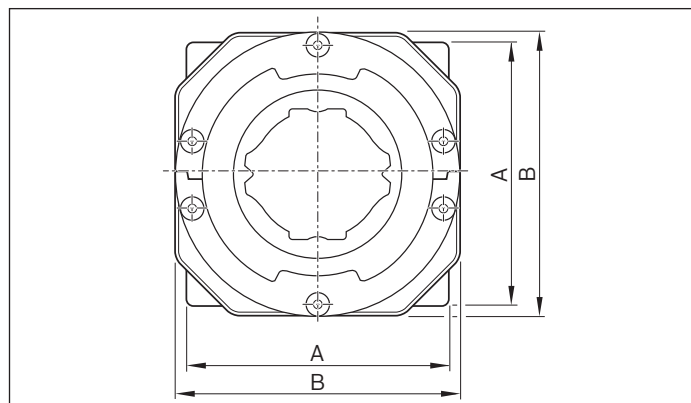

Size	Dimensions (mm)	
	A	B
VKK-050	50	75
VKK-070	70	75
VKK-100	100	100

Cable drag chains

For detailed information see catalog „Connection technology for Linear Motion Systems“

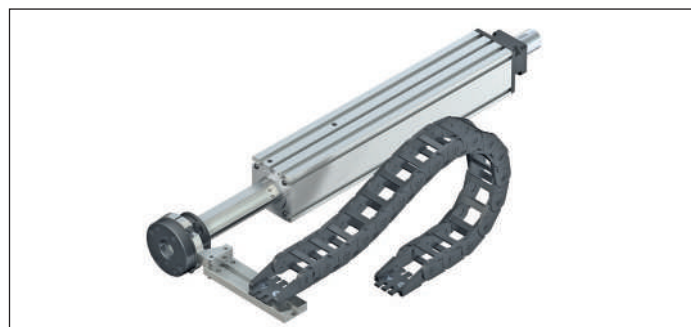

Attachment kits for motors according to customer specification

The motor of a linear motion system with ball screw drive can be mounted using an attachment kit with motor mount and coupling (MF) or a timing belt side drive (RV).

The available combinations are shown in the “Configuration and ordering” selection tables for each size. In addition to motor attachment kits for Rexroth motors, attachment kits for motors according to customer specification can also be ordered. The connection geometry of the motor is essential for determining the right attachment kit. Characteristics required to clearly determine motor geometry are shown below.

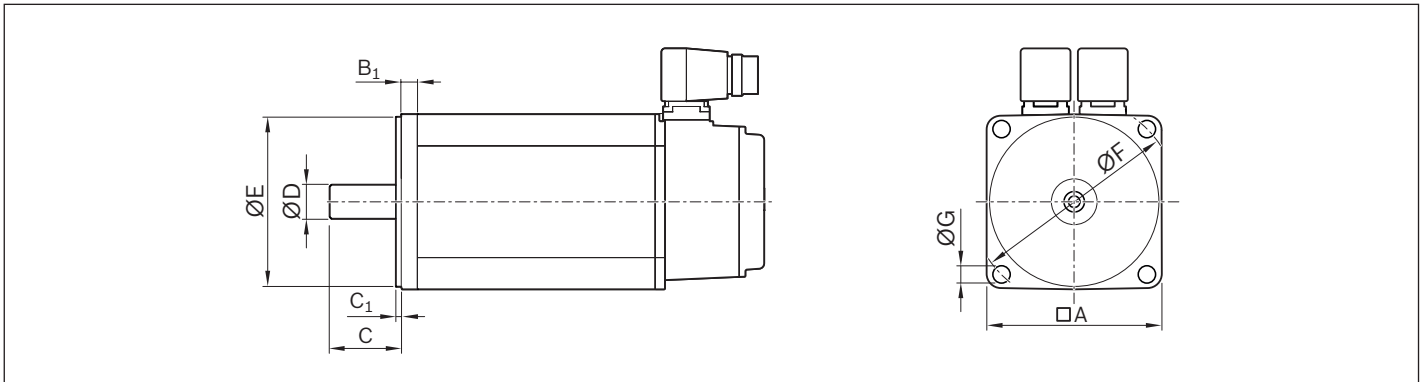

The entered dimensions produce a unique “motor geometry code”:

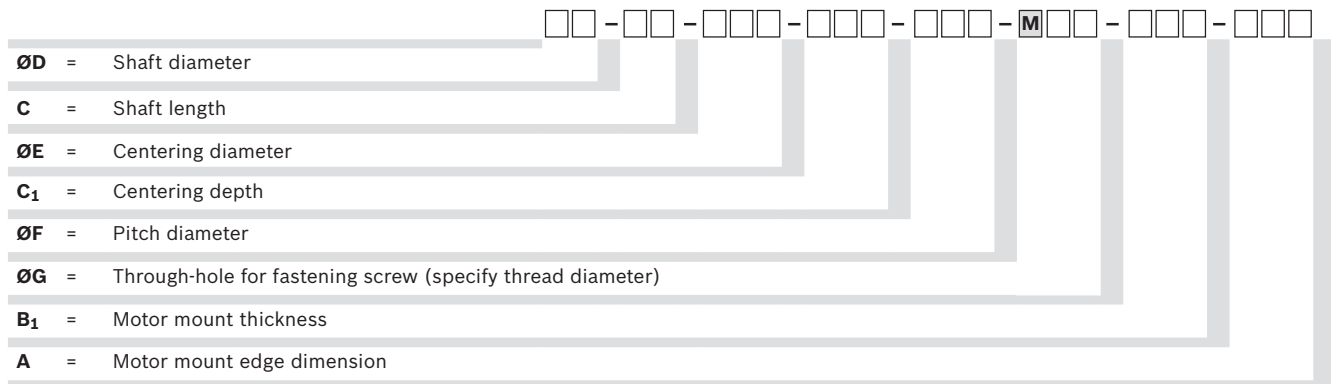

Example illustration of servo motor IndraDyn S Type MSK040C

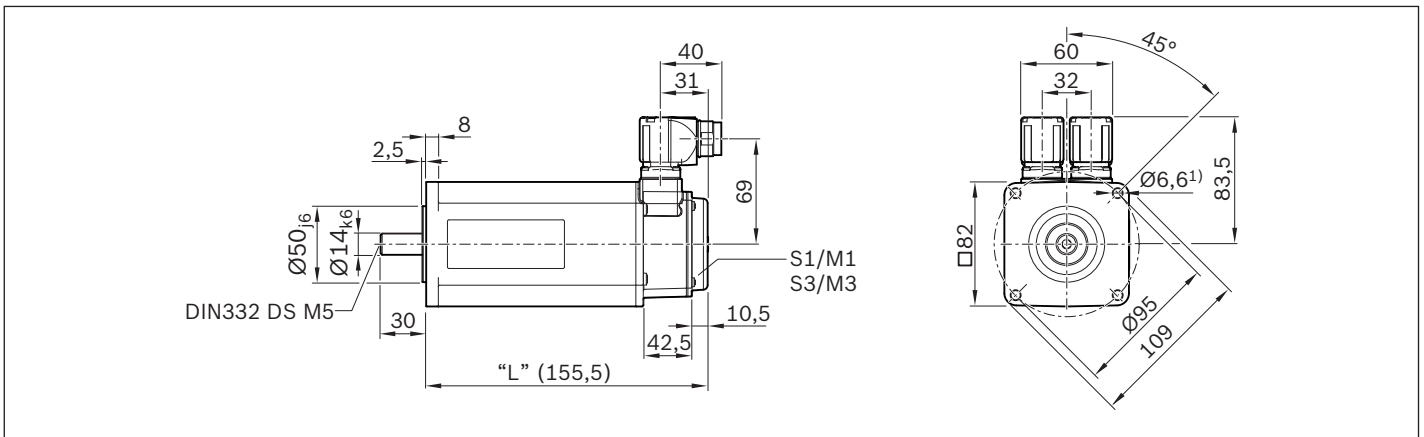

1 4 - 3 0 - 0 5 0 - 2 . 5 - 0 9 5 - M 0 6 - 0 0 8 - 0 8 2

1 The 6.6 mm diameter through-hole results in the type designation M06 for the motor geometry code (M6 nominal fastening screw thread diameter).

Attachment kits for motors according to customer specification can be configured using the online configuration tool in the eShop. This requires the “attachment kits for motors according to customer specification” option to be selected.

An input dialog box is available for entering motor geometry. The dimensions can be entered directly or by a drop-down menu.

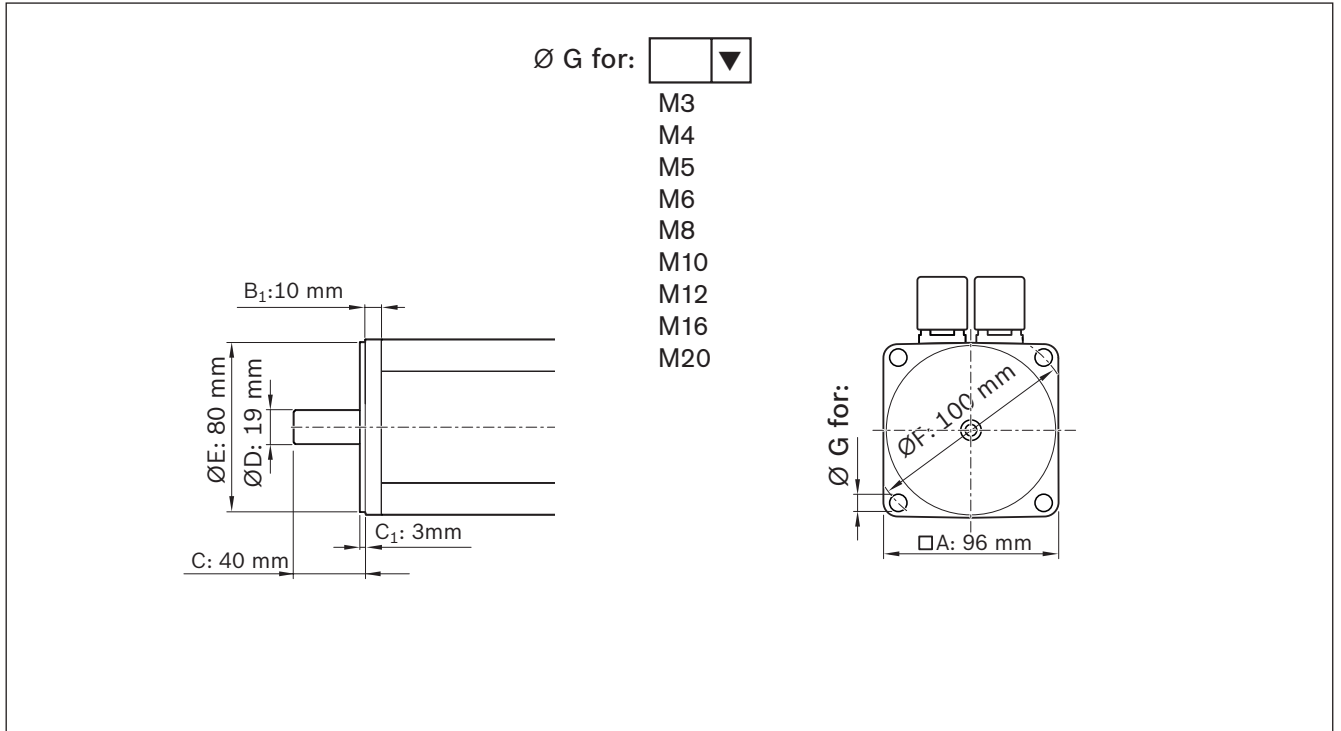

IndraDyn S - MSK servo motor



Motor schematic

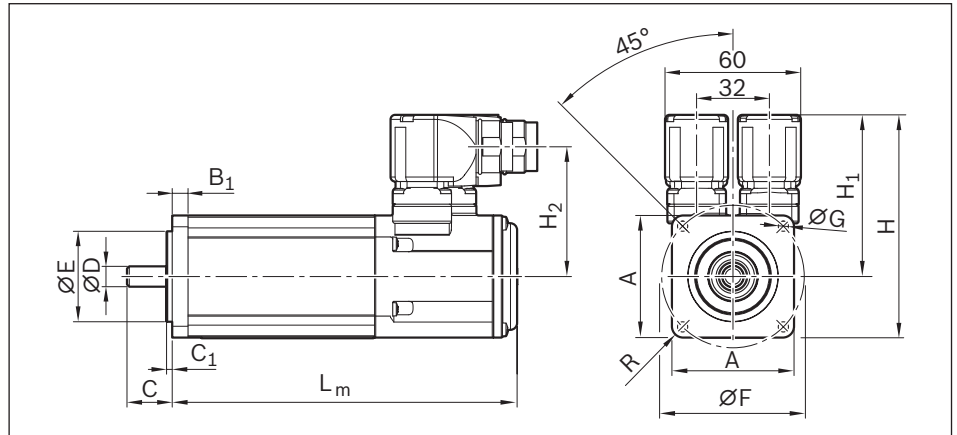

Dimensions

Motor	Dimensions (mm)								L _m	
	A	C	ØD k6	ØE j6	ØF	ØG	H	without holding brake	with holding brake	
MSK 030C-0900	54	20	9	40	63	4.5	98.5	180.0	213.0	
MSK 040C-0600	82	30	14	50	95	6.6	124.5	185.5	215.5	
MSK 050C-0600	98	40	19	95	115	9.0	134.5	203.0	233.0	

Motor data

Motor	n _{max} (rpm)	M ₀ (Nm)	M _{max} (Nm)	M _{br} (Nm)	J _m (kgm ²)	J _{br} (kgm ²)	mm (kg)	m _{br} (kg)
MSK 030C-0900	9 000	0.8	4.0	1	0.000030	0.000007	1.9	0.2
MSK 040C-0600	7 500	2.7	8.1	4	0.000140	0.000023	3.6	0.3
MSK 050C-0600	6 000	5.0	15.0	5	0.000330	0.000107	5.4	0.7

J_{br} = mass moment of inertia of the holding brake
 J_m = mass moment of inertia of the motor
 L_m = length of the motor
 M₀ = standstill torque

M_{br} = holding torque of holding brake when switched off
 M_{max} = maximum possible motor torque
 m_{br} = mass of the holding brake
 n_{max} = maximum motor speed

Torque/speed characteristic (schematic)

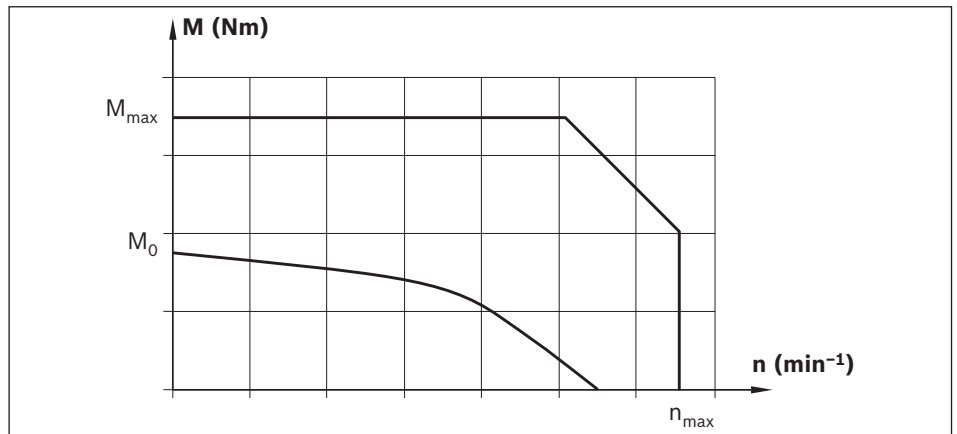

Option number ¹⁾	Motor	Part number	Version holding brake		Type designation
			without	with	
84	MSK 030C-0900	R911308683	X		MSK030C-0900-NN-M1-UG0-NNNN
85		R911308684		X	MSK030C-0900-NN-M1-UG1-NNNN
86	MSK 040C-0600	R911306060	X		MSK040C-0600-NN-M1-UG0-NNNN
87		R911306061		X	MSK040C-0600-NN-M1-UG1-NNNN
88	MSK 050C-0600	R911298354	X		MSK050C-0600-NN-M1-UG0-NNNN
89		R911298355		X	MSK050C-0600-NN-M1-UG1-NNNN

¹⁾ from the “Components and ordering” table

Version:

- ▶ Plain shaft with shaft seal ring
- ▶ M1 multi-turn absolute encoder (Hiperface)
- ▶ Cooling system: natural convection
- ▶ IP65 rating (housing)
- ▶ With or without holding brake

Note

The motors are available complete with control units and controllers. For further motor types and more information on motors, controllers and control systems, please refer to the following Rexroth catalogs on drive technology:

Rexroth Media Directory

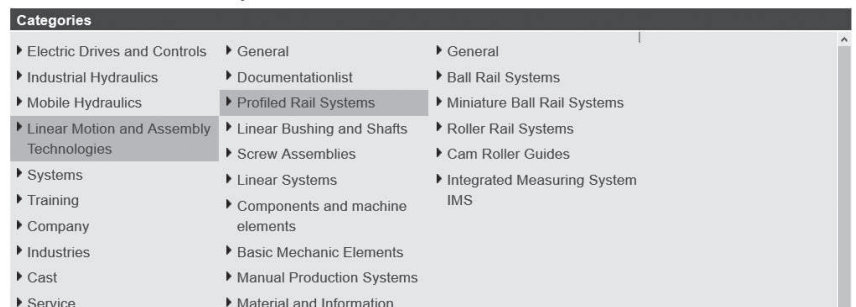

**Recommended motor/
controller combinations**

Motor	Controller
MSK 030C-0900	HCS 01.1E-W0005
MSK 030C-0900	HCS 01.1E-W0008
MSK 040C-0600	
MSK 040C-0600	HCS 01.1E-W0018
MSK 050C-0600	
MSK 050C-0600	HCS 01.1E-W0028
MSK 060C-0600	
MSK 060C-0600	HCS 01.1E-W0054
MSK 076C-0450	



IndraDyn S - servo motors MSM

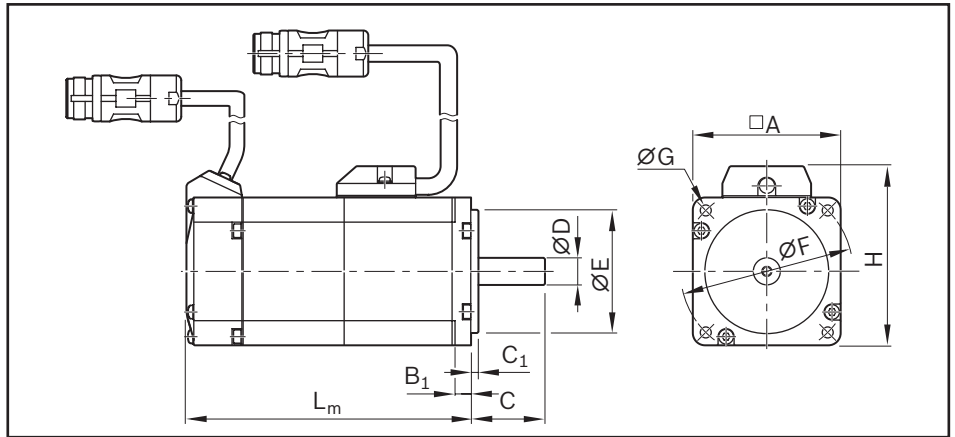

Motor schematic

Dimensions

Motor	Dimensions (mm)										L_m	
	A	B ₁	C	C ₁	ØD h6	ØE h7	ØF	ØG	H	without holding brake	with holding brake	
MSM 019B-0300	38	6.0	25	3	8	30	45	3.4	51	92.0	122.0	
MSM 031B-0300	60	6.5	30	3	11	50	70	4.5	73	79.0	115.5	
MSM 031C-0300	60	6.5	30	3	14	50	70	4.5	73	98.5	135.0	
MSM 041B-0300	80	8.0	35	3	19	70	90	6.0	93	112.0	149.0	

Motor data

Motor	n_{max} (rpm)	M_0 (Nm)	M_{max} (Nm)	M_{br} (Nm)	J_m (kgm ²)	J_{br} (kgm ²)	mm (kg)	m_{br} (kg)
MSM 019B-0300	5 000	0.32	0.95	0.29	0.0000051	0.0000002	0.47	0.21
MSM 031B-0300	5 000	0.64	1.91	1.27	0.0000140	0.0000018	0.82	0.48
MSM 031C-0300	5 000	1.30	3.80	1.27	0.0000260	0.0000018	1.20	0.50
MSM 041B-0300	4 500	2.40	7.10	2.45	0.0000870	0.0000075	2.30	0.80

J_{br} = mass moment of inertia of the holding brake
 J_m = mass moment of inertia, motor
 L_m = length of the motor
 M_0 = standstill torque

M_{br} = holding torque of holding brake when switched off
 M_{max} = maximum possible motor torque
 m_{br} = mass of the holding brake
 n_{max} = maximum motor speed

Torque/speed characteristic (schematic)

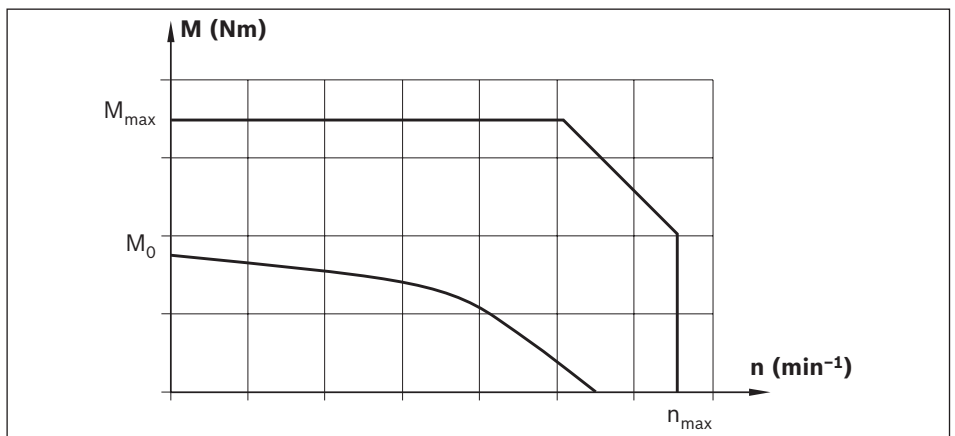

Option number ¹⁾	Motor	Part number	Version		Type designation
			holding brake without	with	
134	MSM019B-0300	R911344211	X		MSM 019B-0300-NN-M5-MH0
135		R911344212		X	MSM 019B-0300-NN-M5-MH1
136	MSM 031B-0300	R911344213	X		MSM 031B-0300-NN-M5-MH0
137		R911344214		X	MSM 031B-0300-NN-M5-MH1
138	MSM 031C-0300	R911344215	X		MSM 031C-0300-NN-M5-MH0
139		R911344216		X	MSM 031C-0300-NN-M5-MH1
140	MSM 041B-0300	R911344217	X		MSM 041B-0300-NN-M5-MH0
141		R911344218		X	MSM 041B-0300-NN-M5-MH1

¹⁾ From the “Configuration and ordering” table

Version:

- ▶ Plain shaft without shaft seal ring
- ▶ Multiturn absolute encoder M5 (20 bit, absolute encoder functionality only possible with back-up battery)
- ▶ Cooling system: natural convection
- ▶ IP54 rating (shaft IP40)
- ▶ With or without holding brake
- ▶ M17 metal round connector

Note

The motors are available complete with control units and controllers. For further motor types and more information on motors, controllers and control systems, please refer to the following Rexroth catalogs on drive technology:

Rexroth Media Directory

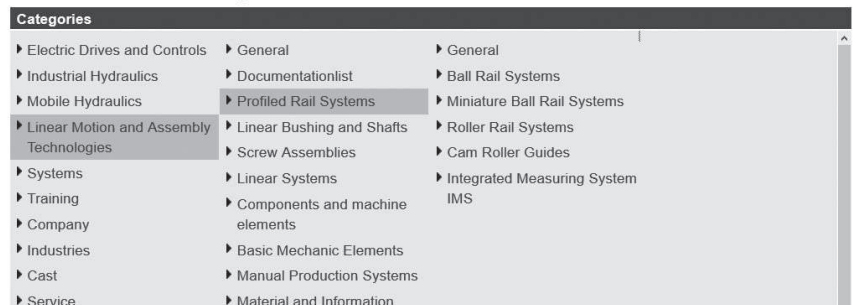

Recommended motor/controller combination

Motor	Controller
MSM 019A-0300	HCS 01.1E-W0003
MSM 019B-0300	
MSM 031B-0300	HCS 01.1E-W0006
MSM 031C-0300	HCS 01.1E-W0009
MSM 041B-0300	HCS 01.1E-W0013

Switch Mounting Arrangements

1 Switch
(magnetic field sensor)

2 T-slot for switches

3 Cable

The switch activator is a magnet integrated in the thrust rod.

Note

For short-stroke applications:
Consider the length of the switch!

Note for mounting

The magnetic field sensors (MFS) are pushed into the T-slot for switches and fixed with set screws.

The MFS cables are routed along the side of the T-slot for switches (3).

For details regarding the switching position, see “Instructions for Feed Modules.”

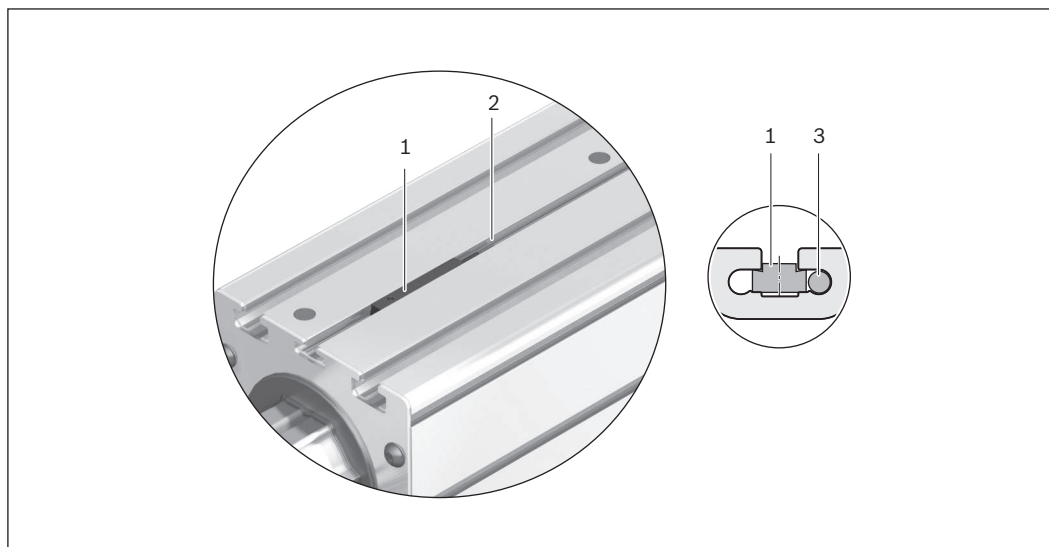
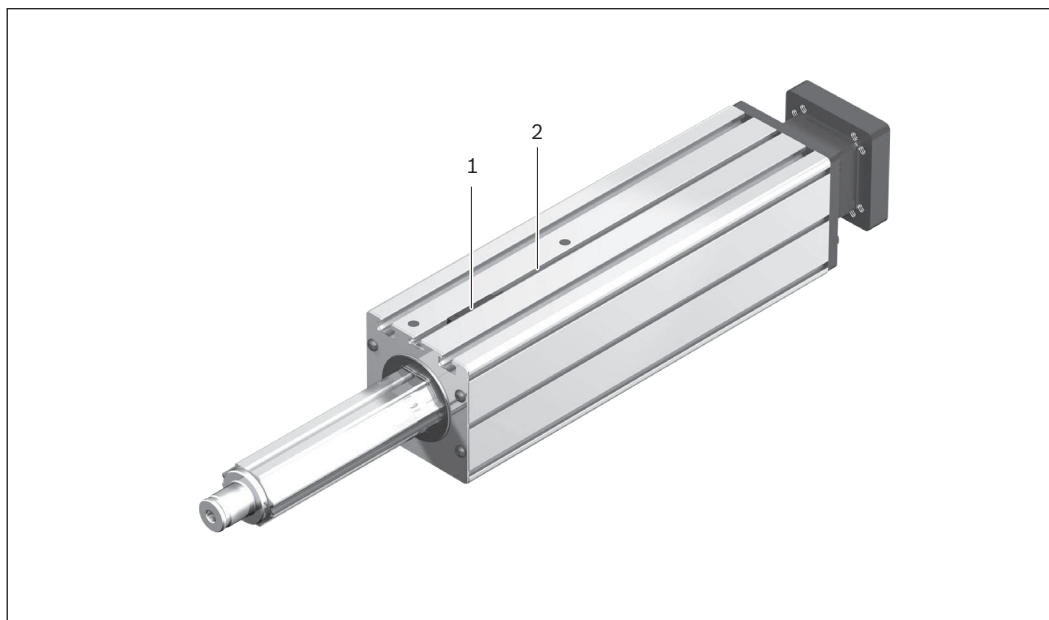

Sensors

Magnetic sensor with open cable end

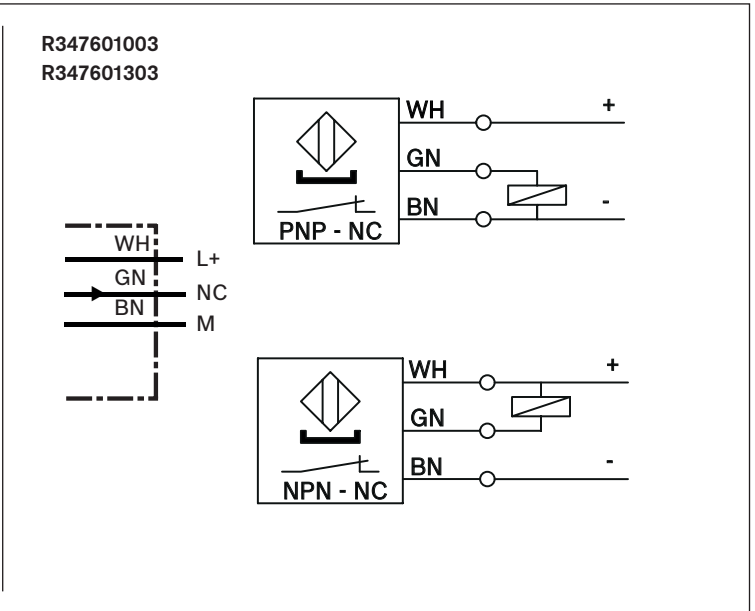
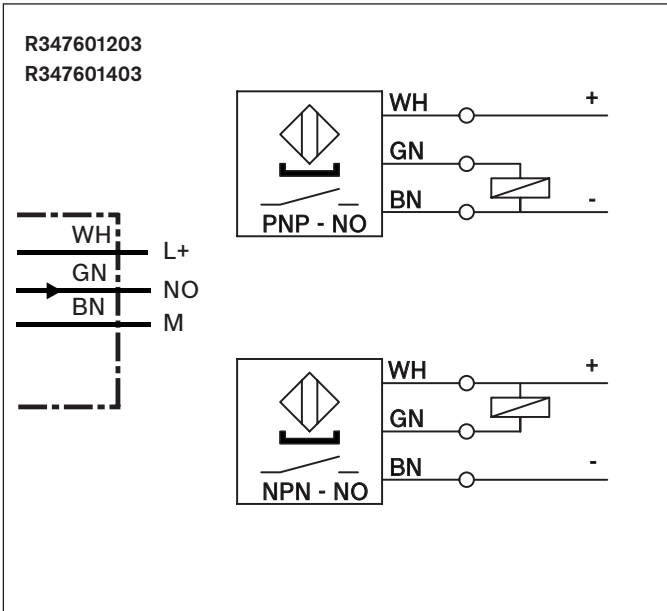
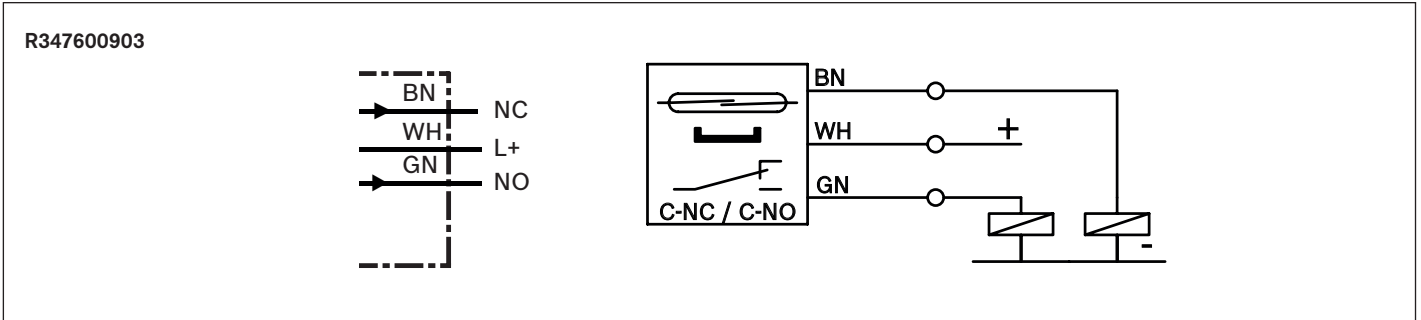
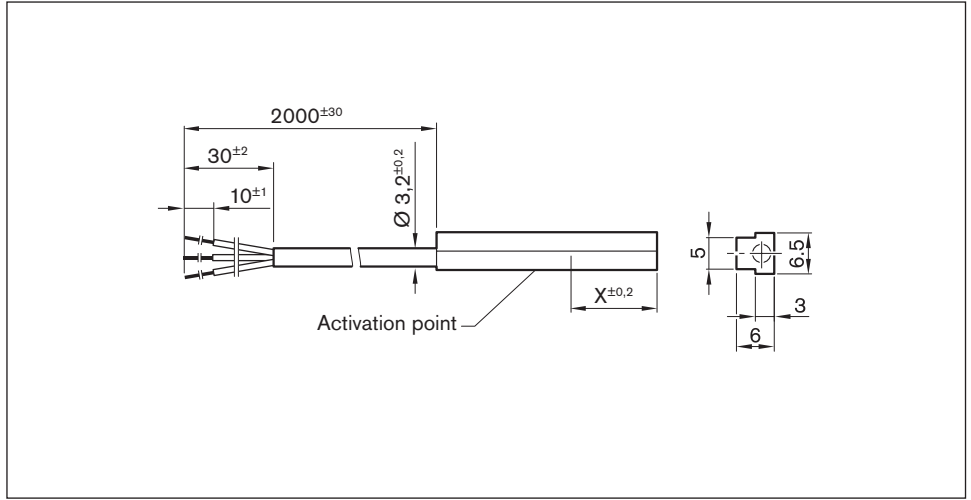
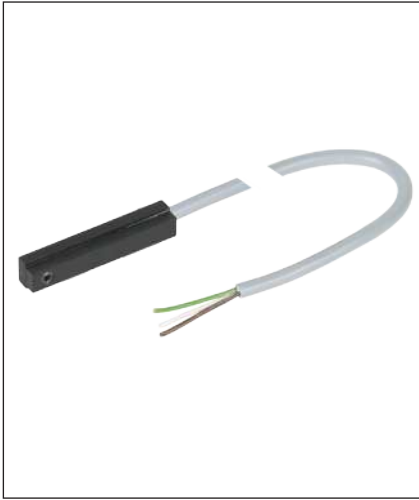

Part number R347600903

Use	Limit switch
Part number	R347600903
Designation	R12212
Function principle	Magnetic
Operating voltage	max. 30 V DC
Load current	500 mA
Switching function	REED/changeover contact: (NC: C+NC, NO: C+NO)
Activation point (dimension "X")	9 mm

Part numbers R347601003 / R347601203 / R347601403 / R347601303

Use	Limit switch	Reference switch	Limit switch	Reference switch
Part number	R347601003	R347601203	R347601303	R347601403
Designation	H14118	H15637	H15638	H15080
Function principle	Magnetic			
Operating voltage	3.8 - 30 V DC			
Load current	≤ 20 mA			
Switching function	Hall PNP/normally closed (NC)	Hall PNP/normally open (NO)	Hall NPN/normally closed (NC)	Hall NPN/normally open (NO)
Activation point (dimension "X")	13.65 mm			

Technical data for R347600903 / R347601003 / R347601203 / R347601403 / R347601303

Connection type	Cable 2,0 m, 3-pin
Galvanized connection ends	✓
Function indication	—
Short-circuit protection	—
Reverse polarity protection	—
Switch-on suppression	—
Switching frequency	2.5 kHz
Pulse delay (Off delay)	—
Max. permissible approach speed	2 m/s
Suitable for flexing installation*	—
Torsion-resistant*	—
Weld spark-resistant*	—
Wire gauge*	3 x 0.14 mm ²
Cable diameter D	3.2 ± 0.20 mm
Static bending radius*	—
Dynamic bending radius*	—
Bending cycles*	—
Max. permissible speed*	—
Max. permissible acceleration*	—
Ambient temperature	-40 °C bis +85 °C
Protection rating	IP66
MTTFd (in accordance with EN ISO 13849-1)	—
Certifications and approvals**	—

*) Technical data only for the one-piece connection cable on the sensor.

The available extension cables offer even better performance, e.g., when using a power cable chain (see following pages).

**) No  certificate necessary for these products for introduction into the Chinese market.

Sensors

Magnetic sensor with M8x1 plug

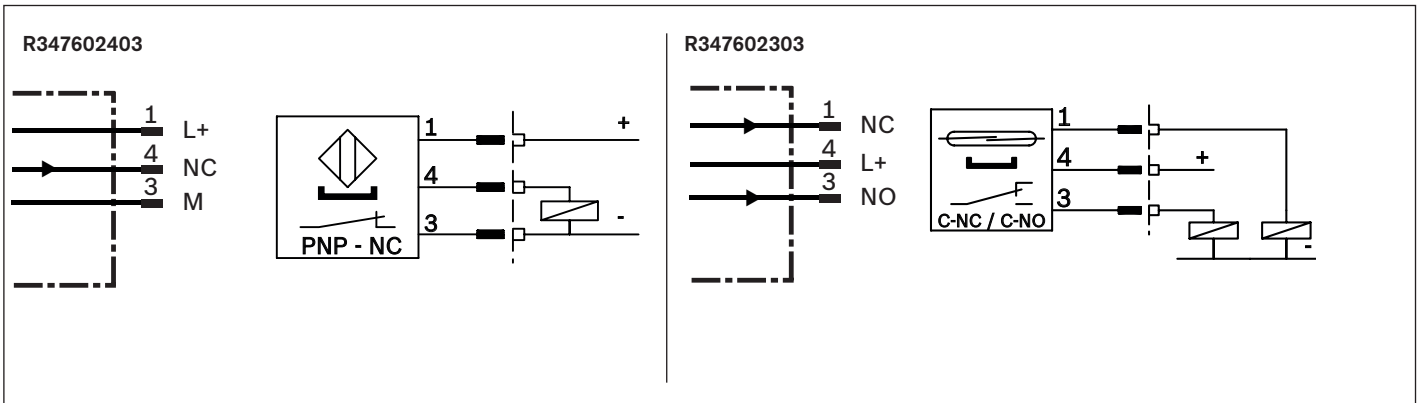
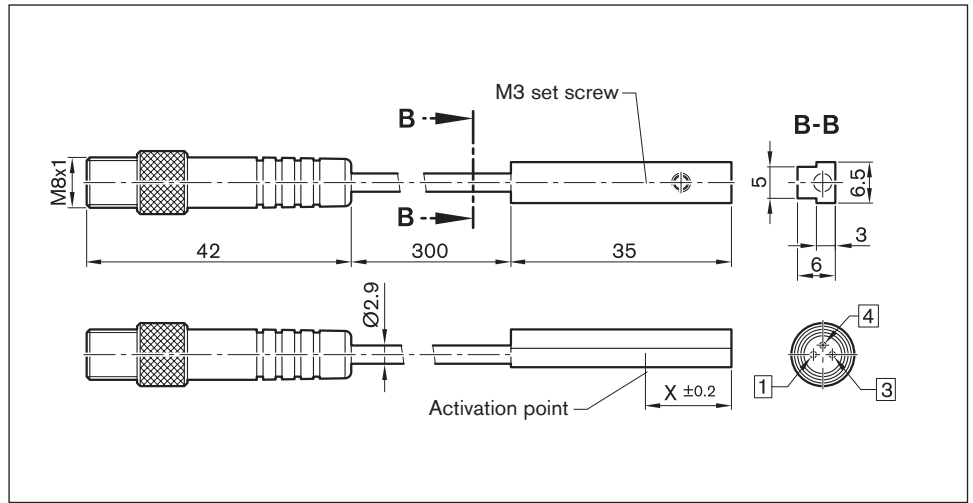

Part numbers/technical data

Use	Limit switch	Limit switch
Part number	R347602403	R347602303
Designation	H10706	R10705
Function principle	Magnetic	
Operating voltage	3.8 - 30 V DC	30 V DC
Load current	≤ 20 mA	500 mA
Switching function	Hall PNP/normally closed (NC)	REED/single-pole changeover (NC: C+NC, NO: C+NO)
Activation point (dimension "X")	13.65 mm	9 mm
Connection type	Cable 0.3 m and plug M8x1, 3-pin with knurled screws	
Function indication	-	
Short-circuit protection	-	
Reverse polarity protection	-	
Switch-on suppression	-	
Switching frequency	2.5 kHz	
Pulse delay (Off delay)	-	
Max. permissible approach speed	2 m/s	
Suitable for flexing installation*	-	
Torsion-resistant*	-	
Weld spark-resistant*	-	
Wire gauge*	3 x 0.14 mm ²	
Cable diameter D*	3.2 ± 0.20 mm	
Static bending radius*	-	
Dynamic bending radius*	-	
Bending cycles*	-	
Max. permissible speed*	-	
Max. permissible acceleration*	-	
Ambient temperature	-40 °C bis +85 °C	
Protection rating	IP66	
MTTFd (in accordance with EN ISO 13849-1)	-	
Certifications and approvals**	-	

*) Technical data only for the one-piece connection cable (0.3 m) on the magnetic sensor.

The available extension cables offer even better performance, e.g., when using a power cable chain (see following pages).

**) No  certificate necessary for these products for introduction into the Chinese market.

Extension pieces

Pre-assembled on one side

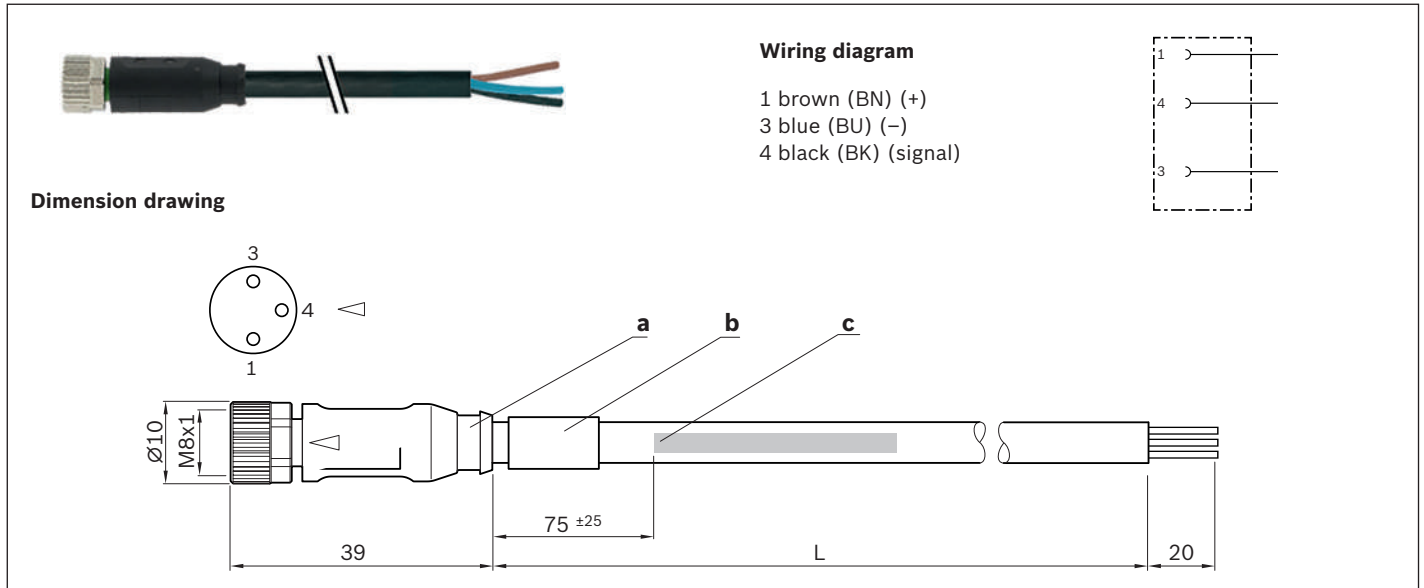

Part numbers

Use	Extension cable		
Part number	R911344602	R911344619	R911344620
Designation	7000-08041-6500500	7000-08041-6501000	7000-08041-6501500
Length (L)	5.0 m	10.0 m	15.0 m
1st connection type	Straight female connector, M8 x 1, 3-pin		
2nd connection type	Open end		

- a) Contour for corrugated tube with 6.5 mm inner diameter
- b) Cable grommet
- c) Cable label in accordance with Labeling Directive



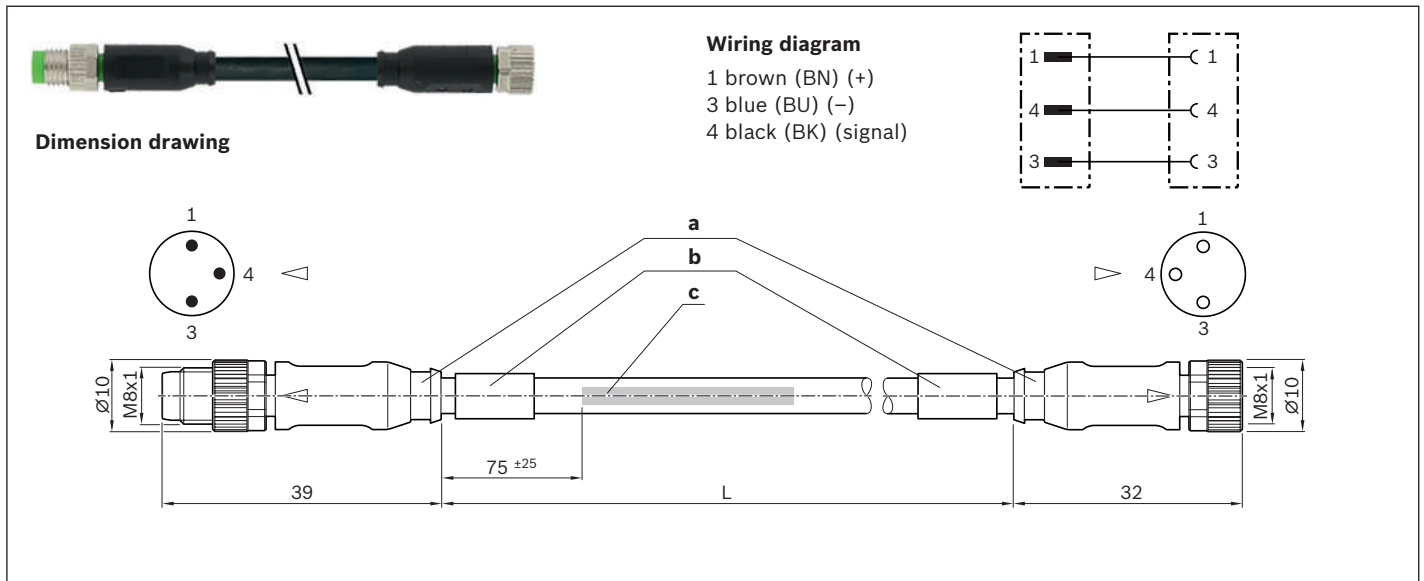

Pre-assembled on two sides



Part numbers



Use	Extension cable				
Part number	R911344621	R911344622	R911344623	R911344624	R911344625
Designation	7000-88001-6500050	7000-88001-6500100	7000-88001-6500200	7000-88001-6500500	7000-88001-6501000
Length (L)	0.5 m	1.0 m	2.0 m	5.0 m	10.0 m
1st connection type	Straight female connector, M8x1, 3-pin				
2nd connection type	Straight plug, M8x1, 3-pin				



Technical data for one-sided and two-sided pre-assembled extension pieces

Function indication	-
Operating voltage indicator	-
Operating voltage	10 - 30 V DC
Cable type	Black polyurethane
Suitable for flexing installation	✓
Torsion-resistant	✓
Weld spark-resistant	✓
Wire gauge	3 x 0.25 mm ²
Cable diameter D	4.1 ±0.2 mm
Static bending radius	≥ 5xD
Dynamic bending radius	≥ 10xD
Bending cycles	> 10 million
Max. permissible travel speed	3.3 m/s over 5 m (typ.) to 5 m/s over 0.9 m
Max. permissible acceleration	≤ 30 m/s ²
Ambient temperature when fixed	-40 °C bis +85 °C
Ambient temperature when flexible	-25 °C to +85 °C
Protection rating	IP68
Certifications and approvals	    

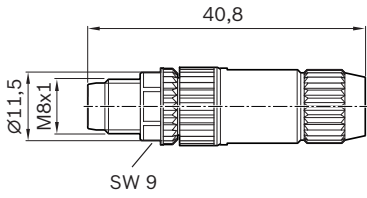
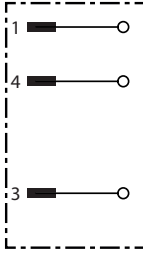
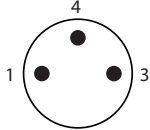
- a) Contour for corrugated tube with 6.5 mm inner diameter
- b) Cable grommet
- c) Cable label in accordance with Labeling Directive

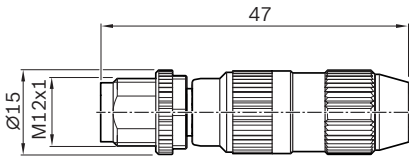
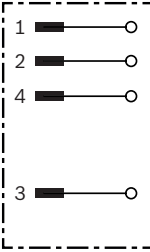
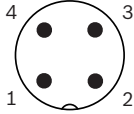
Plugs

	Dimension drawing	Wiring diagram	Plug side view
 R901388333			
 R901388352			

Part numbers/technical data		
Use	Single plug	
Part number	R901388333	R901388352
Designation	7000-08331-0000000	7000-12491-0000000
Version	Straight	
Operating current per contact	Max. 4 A	
Operating voltage	Max. 32 V AC/DC	
Connection type	Straight plug, M8x1, 3-pin, insulation displacement, self-locking screw thread	Straight plug, M12x1, 4-pin, insulation displacement, self-locking screw thread
Function indication	-	
Operating voltage indicator	-	
Connection cross-section	0.14 ... 0.34 mm ²	
Ambient temperature	-25 °C to +85 °C	
Protection rating	IP67 (plugged in & screwed down)	
Certifications and approvals	  	

Adapters



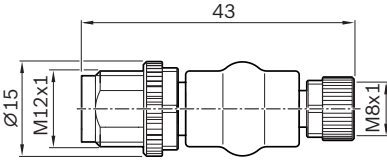

R911344591

Dimension drawing

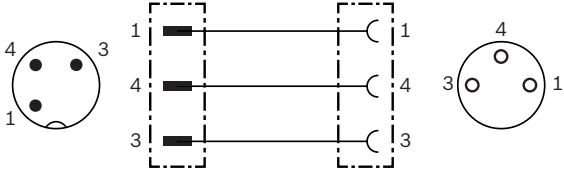

Wiring diagram





R911344592

Dimension drawing

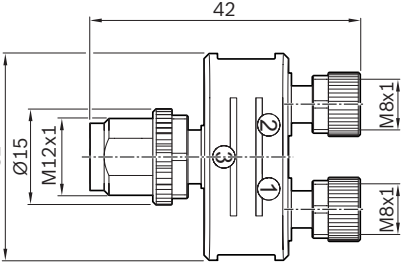



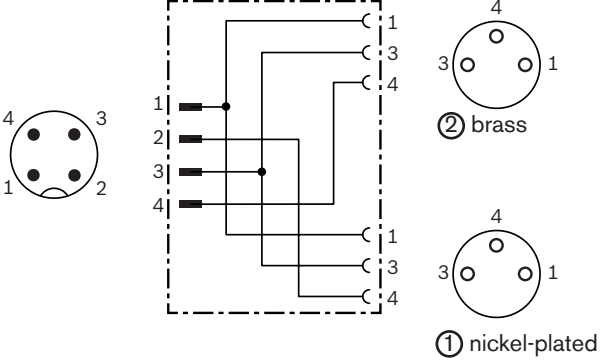

Wiring diagram



② brass

① nickel-plated

Part numbers/technical data

Use	Adapter	Adapter or distributor
Part number	R911344591	R911344592
Designation	7000-42201-0000000	7000-41211-0000000
Version	Straight, for 1 sensor	Straight, for 1 - 2 sensors
Operating current per contact	Max. 4 A	
Operating voltage	Max. 32 V AC/DC	
1st connection type	Straight female connector, M8x1, 3-pin, self-locking screw thread	2 X straight female connector, M8x1, 3-pin, self-locking screw thread
2nd connection type	Straight plug, M12x1, 3-pin, self-locking screw thread	Straight plug, M12x1, 4-pin, self-locking screw thread
Function indication	-	
Operating voltage indicator	-	
Connection cross-section	-	
Ambient temperature	-25 °C to +85 °C	
Protection rating	IP67 (plugged in & screwed down)	
Certifications and approvals		  

Passive distributors

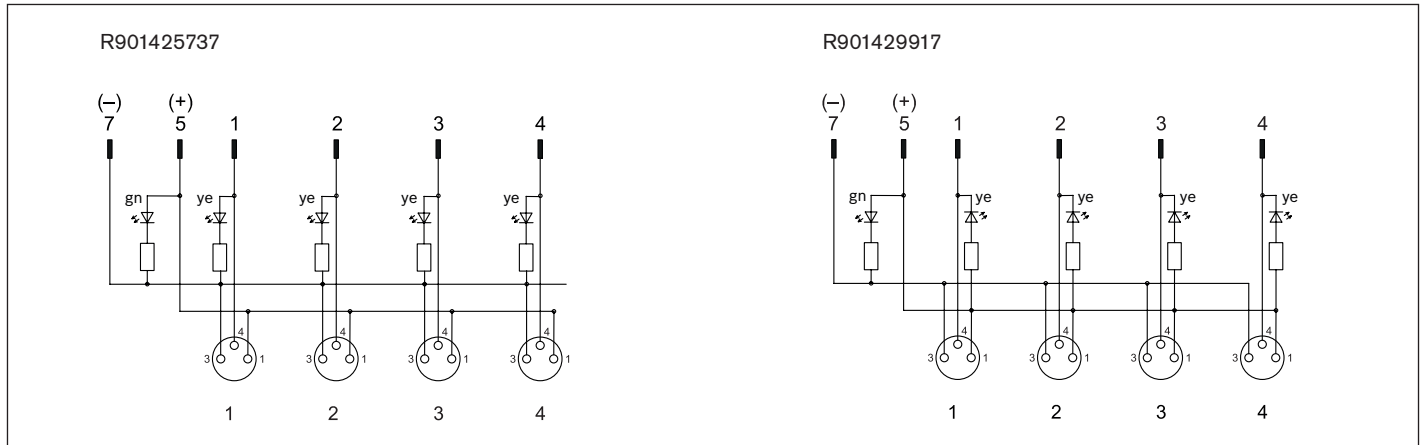
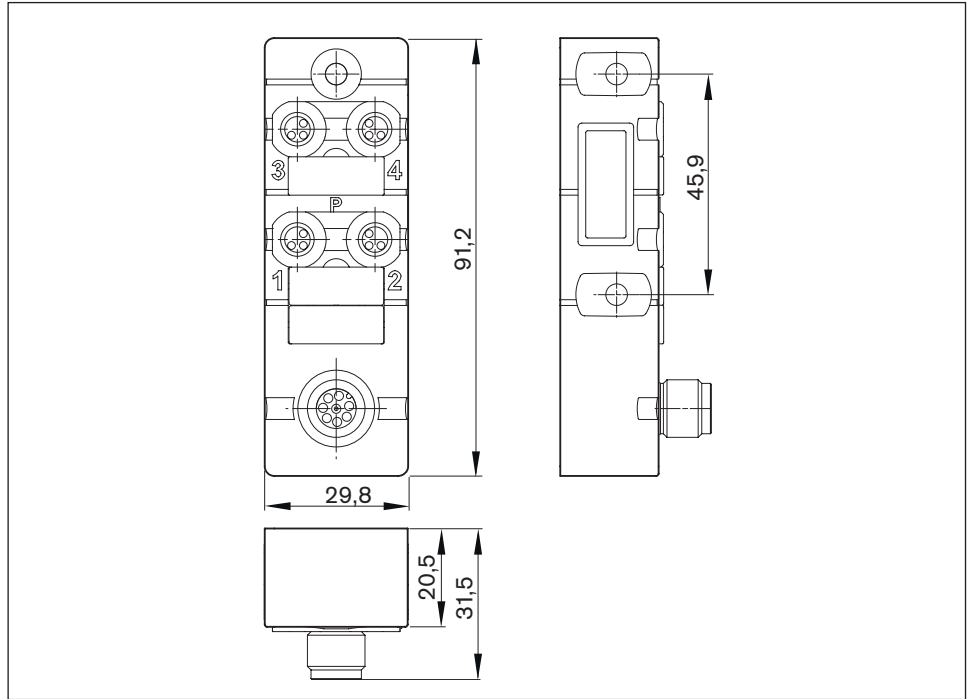

Part numbers/technical data

Use	Passive distributors		
Part number	R901425737	R901429917	R911344592
Designation	8000-84070-0000000	8000-84071-0000000	
Version	Straight, for 1 - 4 sensors		
Operating current per contact	Max. 2 A		
Operating voltage	24 V DC		
Switching logic	PNP	NPN	
1st connection type	4x straight female connector, M8x1, 3-pin, self-locking screw thread		
2nd connection type	Straight plug, M12x1, 8-pin, self-locking screw thread		
Function indication	✓		
Operating voltage indicator	✓		
Connection cross-section	-		
Ambient temperature	-20 °C bis +70 °C		
Protection rating	IP67 (plugged in & screwed down)		
Certifications and approvals			

See "Adapters" for technical data and dimension drawing

Passive distributor accessories

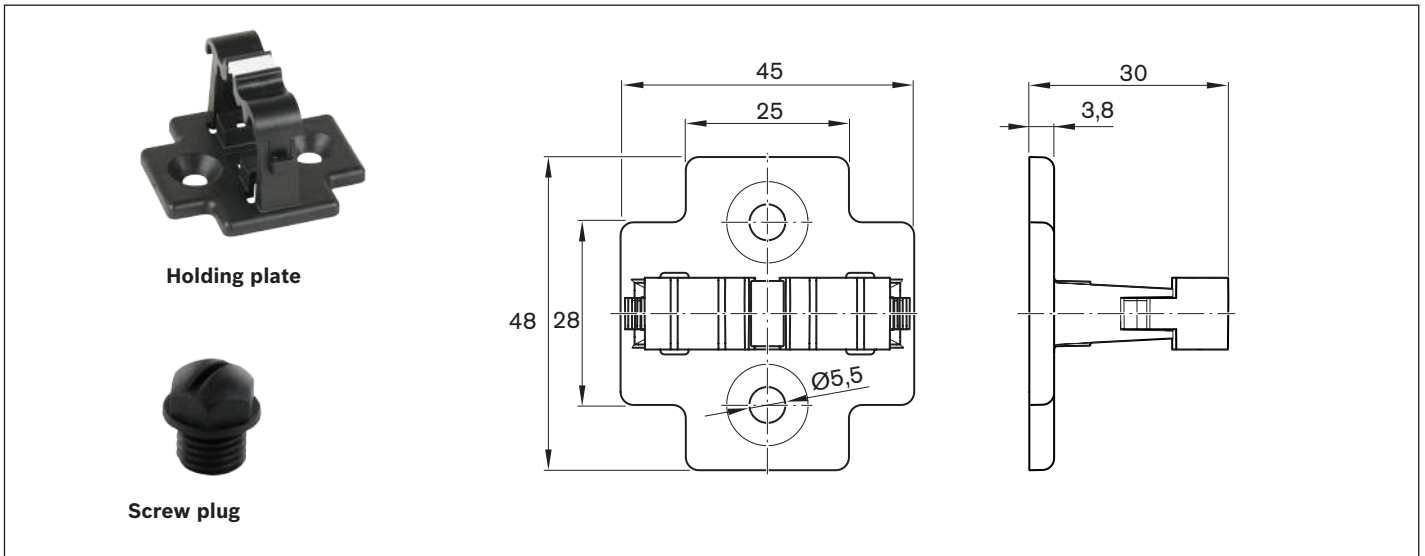

Part numbers/technical data



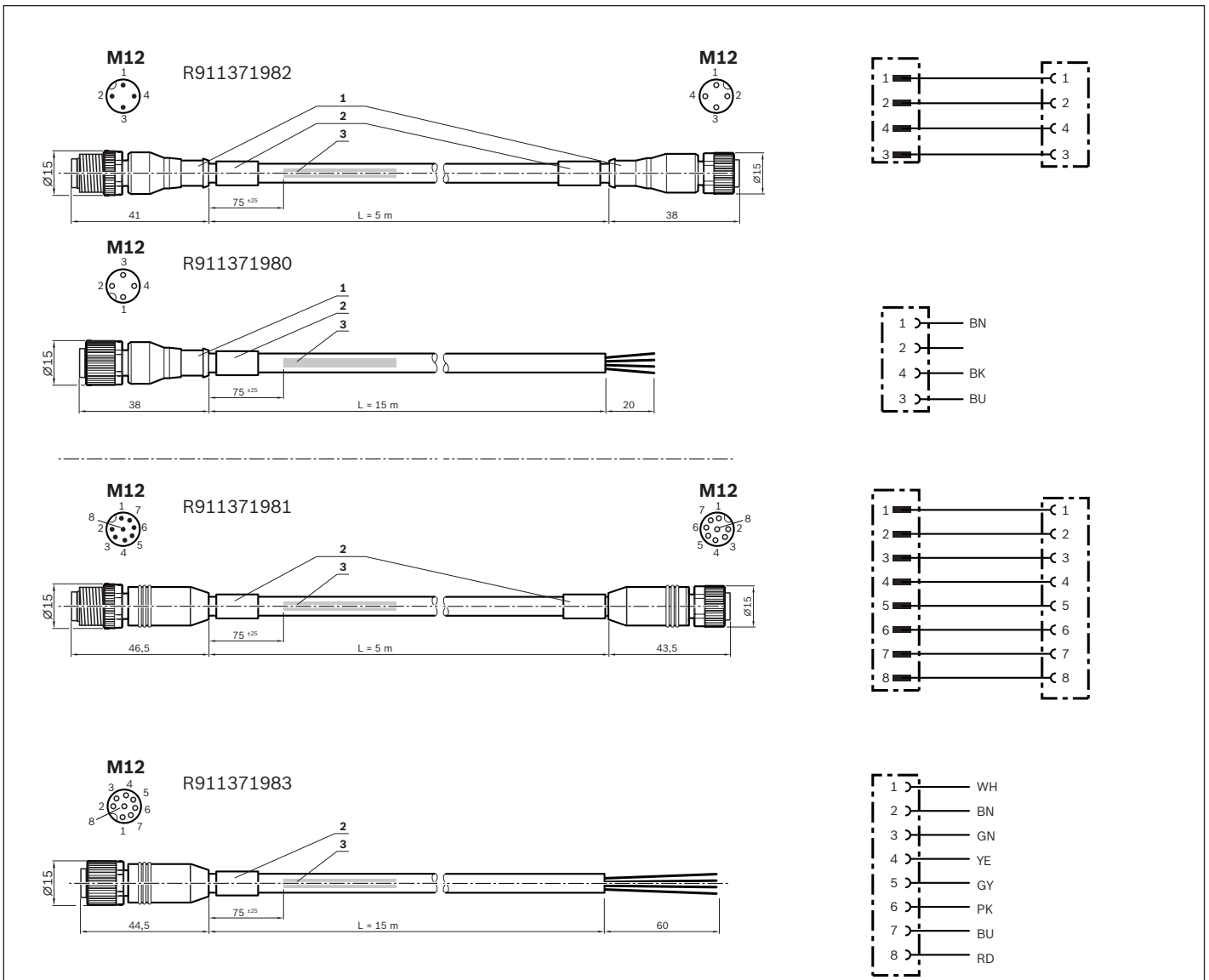

Use	For passive distributor R911344592	For passive distributors R901425737 / R901429917
Holding plate	R913047341	-
Designation	7000-99061-0000000	-
Quantity per set	1 piece	-
Screw plug	-	R913047322
Designation	-	3858627
Quantity per set	-	10 pieces

Extensions for passive distributors



- 1) Contour for 10 mm corrugated tube (inner diameter)
- 2) Cable grommet
- 3) Cable label in accordance with ordering regulation 7000-08001

Part numbers/technical data

Use	Extension cable for passive distributor R911344592		Extension cable for passive distributors R901425737 / R901429917	
Part number	R911371982	R911371980	R911371981	R911371983
Designation	7000-40021-6540500	7000-12221-6541500	7000-48001-3770500	7000-17041-3771500
Length	5.0 m	15.0 m	5.0 m	15.0 m
1st connection type	Straight female connector, M12x1, 4-pin		Straight female connector, M12x1, 8-pin	
2nd connection type	Straight socket, M12x1, 4-pin	Open end	Straight socket, M12x1, 8-pin	Open end
Function indication	-			
Operating voltage indicator	-			
Cable type	Black polyurethane		Gray polyurethane	
Operating voltage	30 V AC/DC			
Operating current per contact	Max. 4 A per contact		Max. 2 A per contact	
Suitable for flexing installation	✓			
Torsion-resistant	✓			
Weld spark-resistant	✓			
Wire gauge	4x 0.34 mm ²		8x 0.34 mm ²	
Cable diameter D	4.7 ± 0.2 mm		6.2 ± 0.3 mm	
Static bending radius	≥ 5 x D			
Dynamic bending radius	≥ 10 x D			
Bending cycles	> 10 million			
Max. permissible travel speed	3.3 m/s over 5 m (typ.) to 5 m/s over 0.9 m			
Max. permissible acceleration	≤ 30 m/s ²			
Ambient temperature when fixed	-40 °C to 80 °C (90° max. 10,000 hrs)			
Ambient temperature when flexible	-25 °C to 80 °C (90° max. 10,000 hrs)			
Protection rating	IP67 (plugged in & screwed down)			
Certifications and approvals	    			

Combination examples

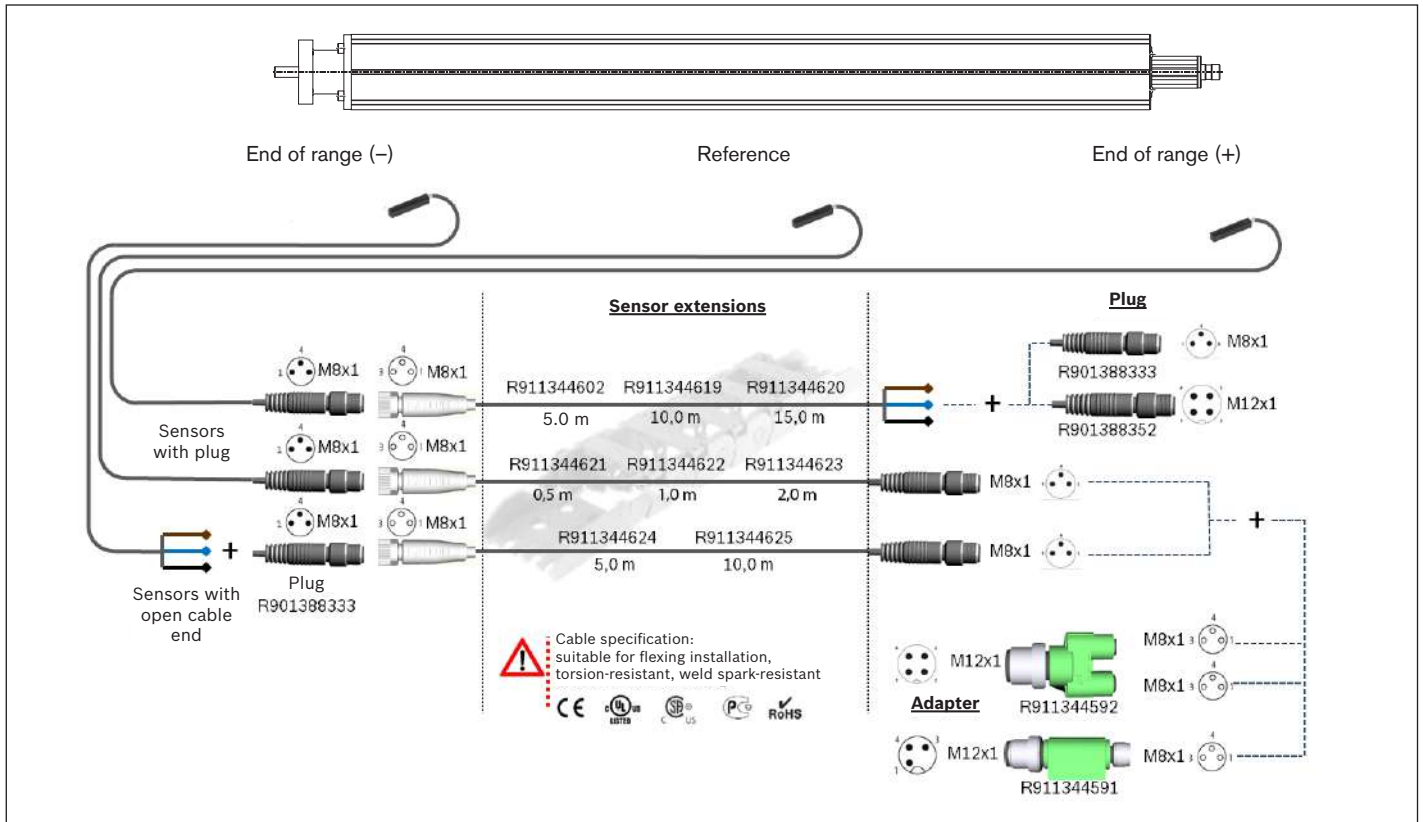

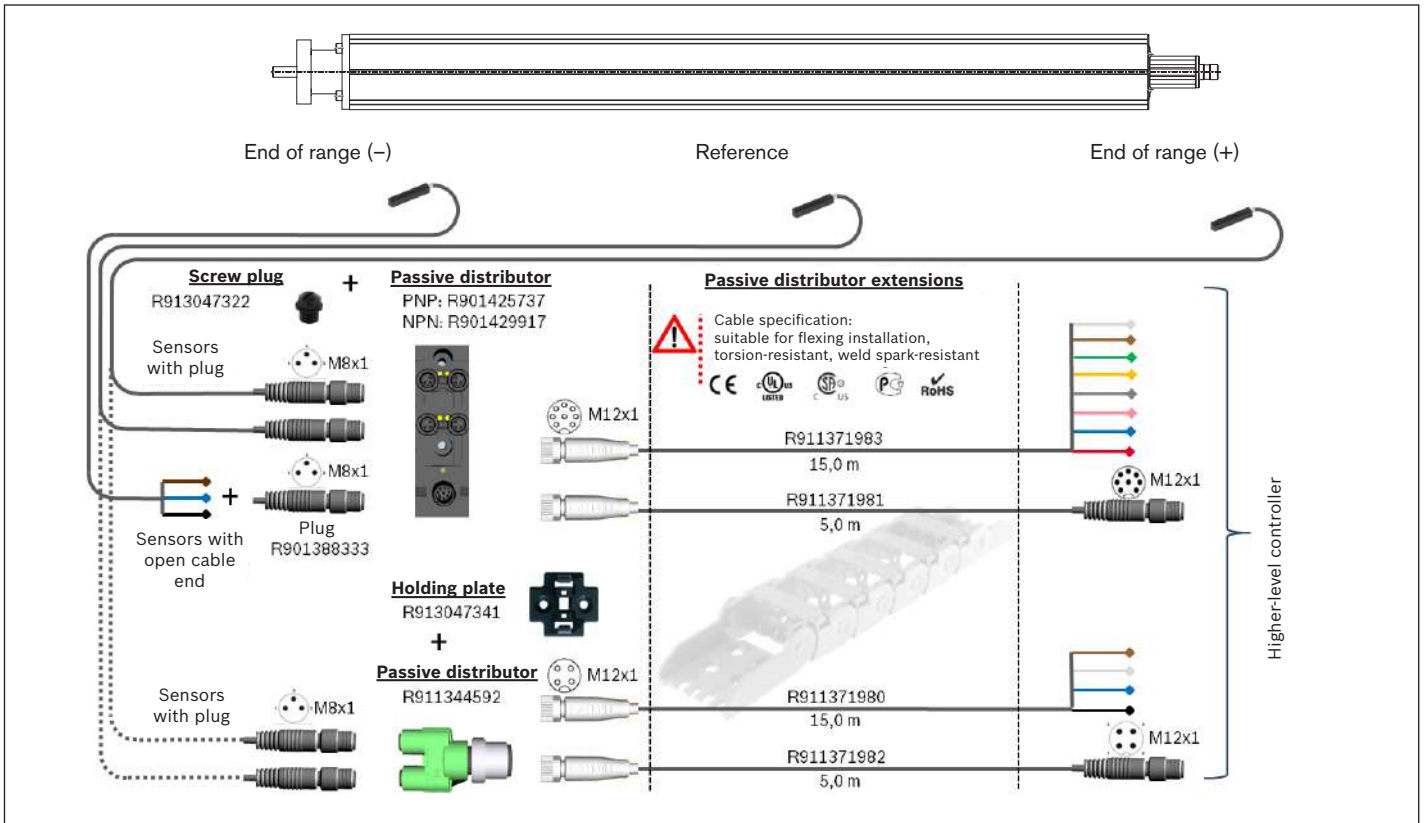

The perfect system solution for every application

Efficient production processes are the key to your success in the marketplace. Today's environment, defined by rapid change and short product cycles, demands flexible systems with an optimal design and configuration. EasyHandling gives you the tools you need to automate your handling tasks with greater ease, speed, and efficiency. EasyHandling is more than just a modular collection of mechanical components; it takes an evolutionary step forward by providing an all-inclusive system solution – our best solution for your requirements.



EasyHandling – Easier. Faster. Better.

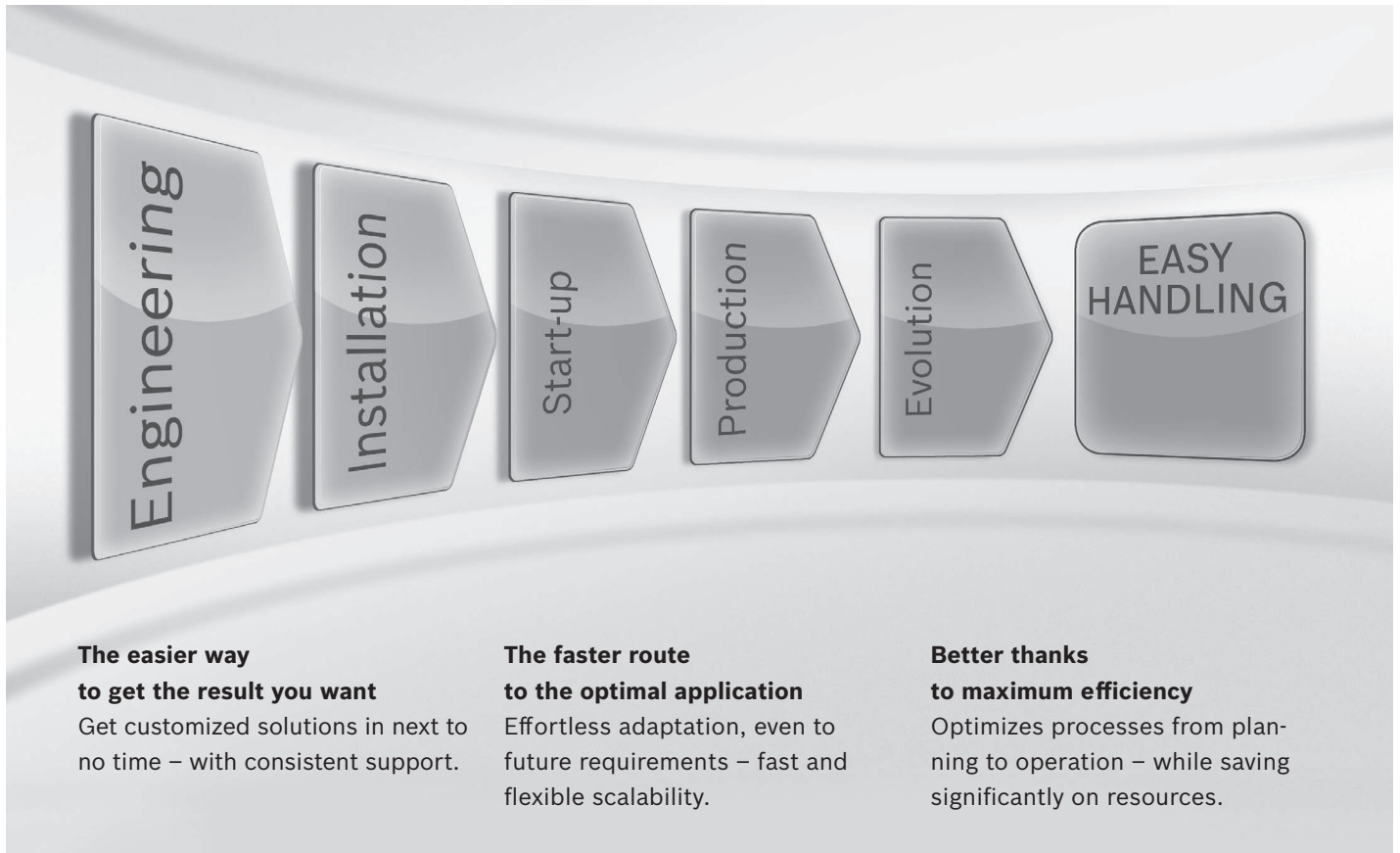

Planning – up to 70% faster

EasyHandling tools help users right from the component selection stage, proposing solutions with all the necessary information on parts lists, technical data and CAD drawings.

Installation – time reduced by up to 60%

Thanks to positive-locking interfaces, mechanical components align perfectly and fit exactly.

Start-up – time reduced by up to 90%

With the EasyWizard smart start-up wizard, parameterization and configuration become child's play. Your handling system will be ready to go in just a few clicks.

Production – more economical and more efficient

Rexroth enhances system effectiveness with smart application tools: The drive controller software outputs maintenance-related messages to the user based on operating hours and travel to help schedule servicing at the right intervals. The result: longer service life and reduced risk of failure.

Further developments – continuous improvement

Be ready for tomorrow's market developments today: One of the great features of EasyHandling systems is their systematic openness. The flexibility of the mechanical and electrical components allows you to adapt quickly and efficiently to new production requirements.

EasyHandling – more than just a building system

The modular system concept
for perfect scalability

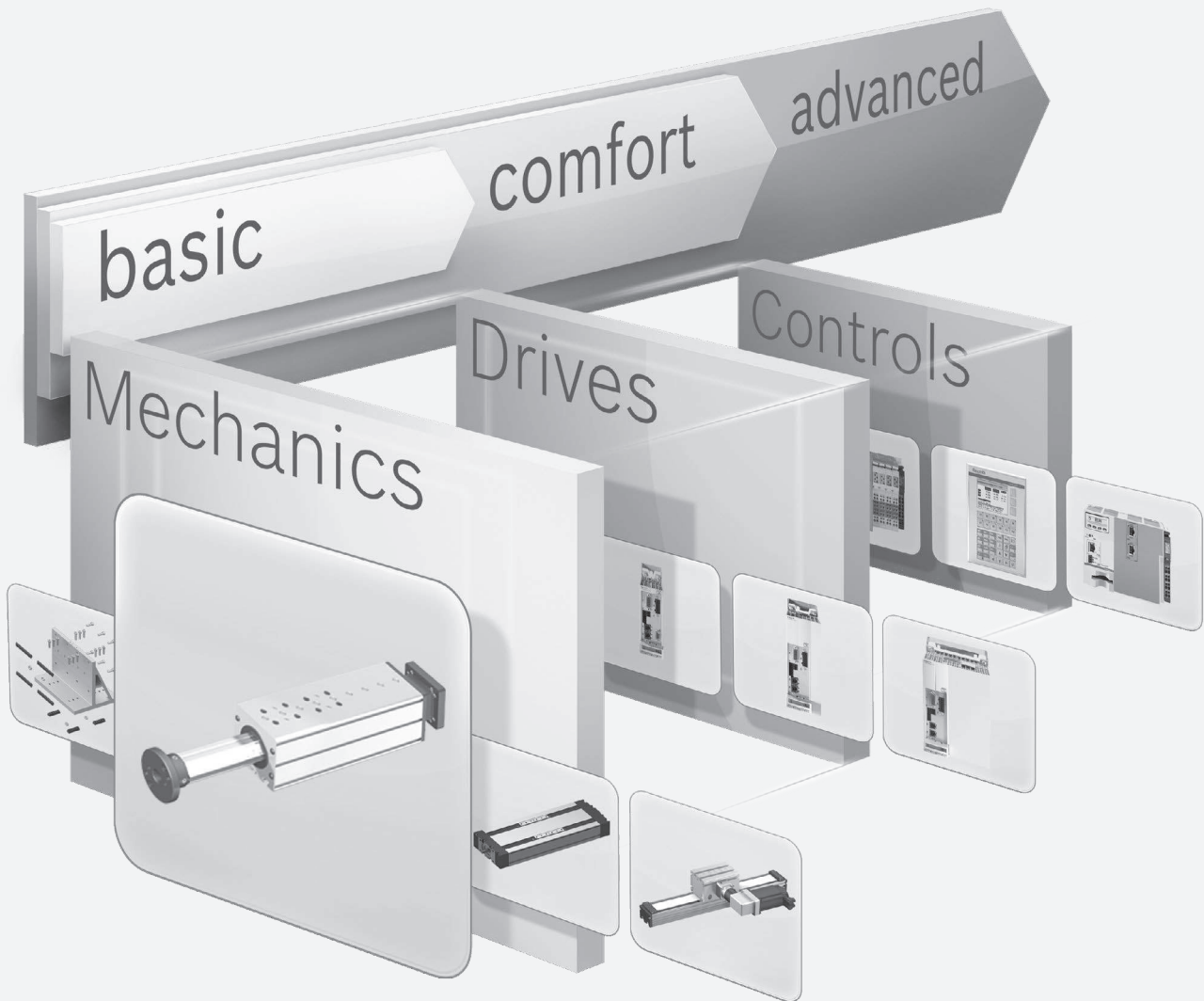

basic – made-to-measure mechanics

EasyHandling basic contains all the mechatronic components you need to build complete, **single or multi-axis systems** to meet your needs.

All of the component interfaces are systematically standardized, making it possible to combine them with ease. Practical tools and aids make selection and configuration even easier.



Comfort – getting started even faster

EasyHandling comfort expands the basic component range by adding **powerful servo drives with multi-protocol capability**. The universal, smart control units are perfectly suited for a variety of handling tasks.

One-of-a-kind: with the **EasyWizard start-up wizard**, linear motion systems are ready to use after entering just a few product-specific parameters.



advanced – controls for demanding requirements

With the **freely scalable, high-performance Motion Logic control system**, EasyHandling advanced makes configuration and handling even easier. Predefined functions covering more than 90 percent of all handling applications eliminate the need for lengthy programming.



For more information about EasyHandling, see the brochure “EasyHandling – more than just a building system” R999000044.



Operating conditions

Normal operating conditions

Ambient temperature with Rexroth servo motor	0 °C ... 40 °C, loss of performance above 40 °C
Ambient temperature for mechanical system (no dropping below dew point)	-10 °C ... 60 °C
Protection rating	IP 54
Motors	Take into account motor temperature limits.

Required and supplementary documentation

For further instructions and information, please refer to documentation for this product.

You can find PDF files of these documents on the Internet at www.boschrexroth.com/mediadirectory

We would also be happy to send you the documents you need.
If you are unsure about using this product, please contact Bosch Rexroth.

Parameterization (start-up)

The nameplate contains reference information on the production of the linear motion system as well as technical parameters for start-up.

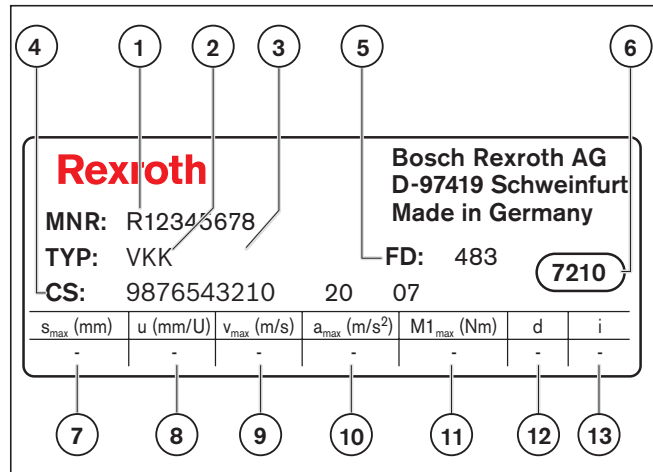

- 1** Part number
- 2** Type designation
- 3** Size
- 4** Customer information
- 5** Date of manufacture
- 6** Manufacturing location
- 7** s_{max} = max. travel range (mm)
- 8** u = lead constant without gear unit (mm/U)
- 9** v_{max} = max. travel speed without gear unit (m/s)
- 10** a_{max} = max. acceleration without gear unit (m/s²)
- 11** $M1_{max}$ = max. drive torque at motor journal (Nm)
- 12** d = motor direction of rotation for travel in positive direction

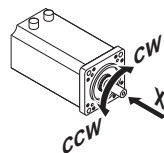

CW = Clockwise
CCW = Counterclockwise

- 13** i = gear ratio

Lubrication and maintenance

Grease lubrication

The advantage of grease lubrication is that ball screw drives can run for prolonged periods without needing relubrication. This means a lubricating system is not required in many cases.

Any high-quality ball bearing lubricating grease can be used. Follow the lubricant manufacturer's instructions. Greases in accordance with DIN 51825 K2K and, for higher loads, KP2K of NLGI grade 2 in accordance with DIN 51818

Notes on lubrication

Basic lubrication is applied in-factory before shipment. Feed Modules are designed for grease lubrication. Only the ball screw drive and guideway require lubrication. No other maintenance is necessary.

Apply lubricant to all lubrication points. To do this, push the thrust rod down to lubricating position "S". When considering adjoining structures, make sure the lubricating position can be reached.

For more information, see "Instructions for VKK".

Lube nipple location

- To access the lube ports, extend the thrust rod to lubricating position **S**.

are recommended for the longest possible lubrication intervals. Tests have shown that greases of NLGI grade 00 achieve only about 50% of the running performance of Class 2 at higher loads.

The lubrication interval depends on many factors, such as degree of contamination, operating temperature, load, etc. Therefore, the following information is for reference only.

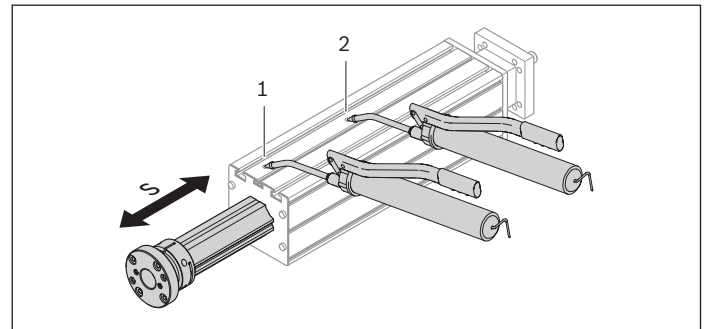

Lube ports for:

- 1) Guideway
- 2) Ball screw drive

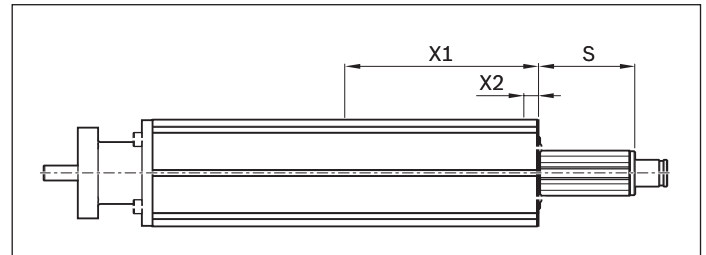

Size	Dimensions (mm)			
	Length	S	X1	X2
VKK-050	240	138	85.0	-5.75 ¹⁾
	280	178		
	360	258		
	480	378		
VKK-070	280	120	123.5	7.50
	320	160		
	400	240		
	520	360		
	600	440		
VKK-100	360	130	154.0	10.00
	400	170		
	480	250		
	600	370		
	680	450		

¹⁾ The lube port is located in a front-mounted lube plate.

Recommended lubricants

Notes on lubrication

Feed Modules receive initial greasing with Dynalub 510 or Dynalub 520 and are only designed for grease lubrication using a manual grease gun.

VKK	Grease (DIN)	Consistency class DIN 51818	Recommended grease	Part number (400 g cartridge)
-050	KP00K (DIN 51825)	NLGI 00	Dynalub 520	R3416 043 00
-070, -100	KP2K (DIN 51826)	NLGI 2	Dynalub 510	R3416 037 00

Lubricant quantities

See "Instructions for feed modules" for lubricant quantities intervals.

⚠ **Do not use greases with solid lubricant components (e.g., graphite or MoS₂ additives).**

Documentation

Standard report Option 01

The standard report serves to confirm that the checks listed in the report have been carried out and that the measured values lie within the permissible tolerances.

Checks listed in the standard report:

- ▶ Functional checks of mechanical components
- ▶ Functional checks of electrical components
- ▶ Design is in accordance with order confirmation

Frictional torque measurement of complete system Option 02

All items as per standard report.

Frictional torque M is measured over the entire travel range.

Example graph

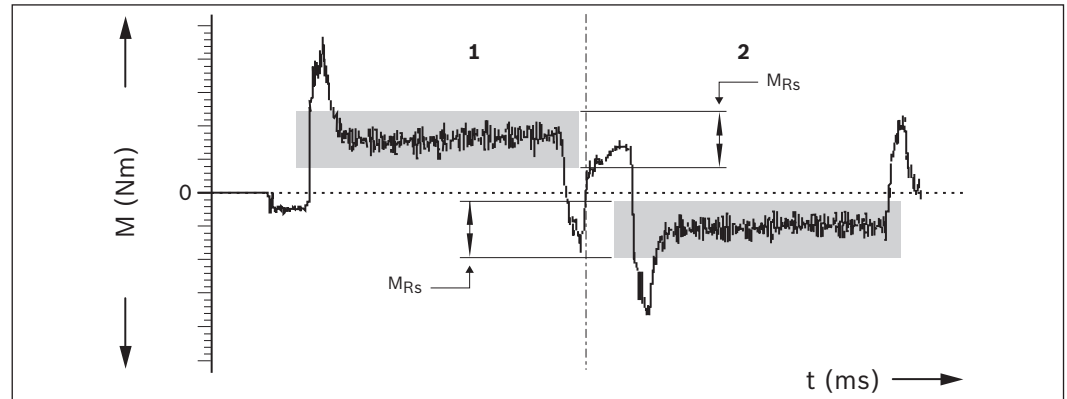

M_{Rs} = Frictional torque (N)
 t = Travel time (ms)

1) Advance
 2) Return

Screw drive lead deviation Option 03

All items as per standard report.

In addition to graph (see figure), a measurement report is included as a table.

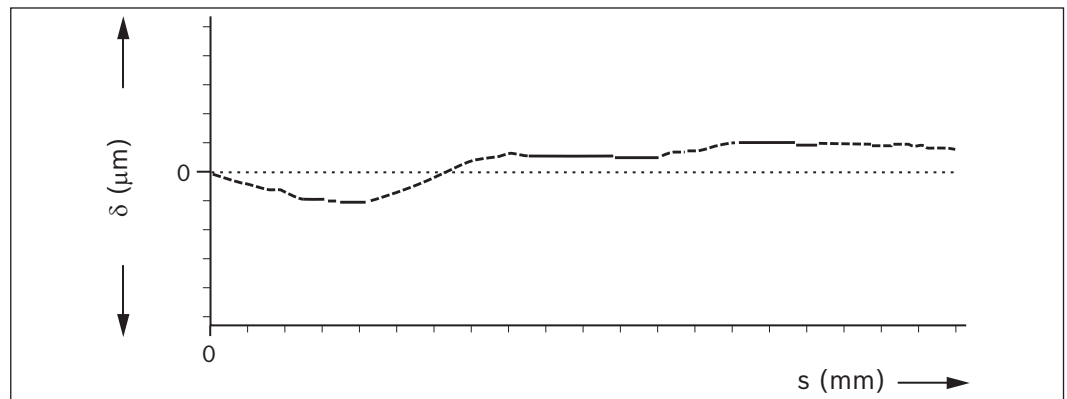

δ = deviation (μm)
 s = measured travel (mm)

Positioning accuracy per VDI/DGQ 3441

Option 05

Measurement points are selected at irregular intervals along the travel range. This allows even periodic deviations δ in μm to be detected during positioning. Each measurement point is approached several times from both sides. This gives the following parameters.

Example graph

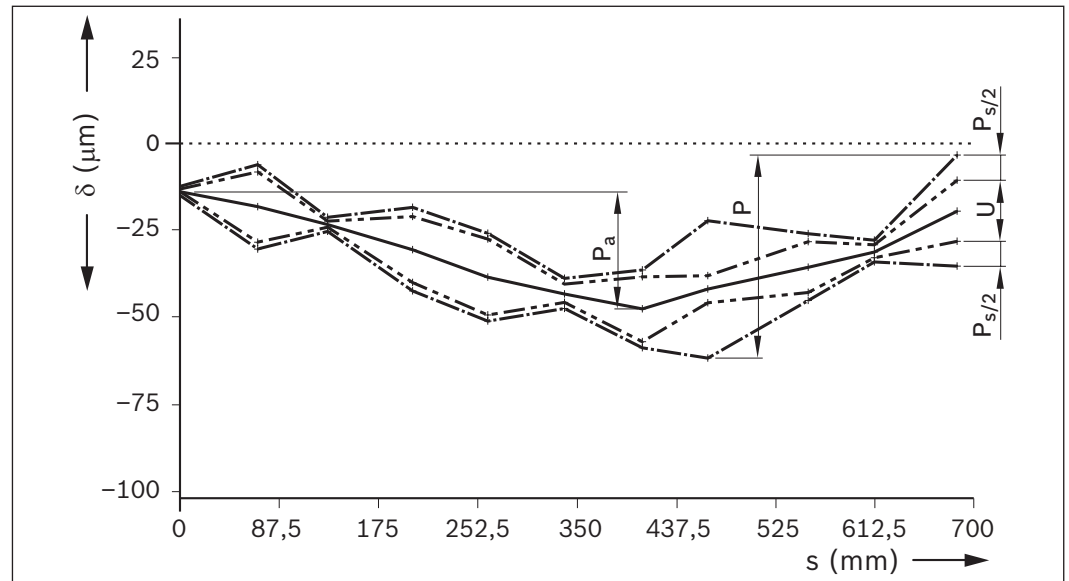

δ = Deviation (μm)
 s = Measured travel (mm)

Positioning accuracy P

The positioning accuracy corresponds to the total deviation.

It includes all systematic and random deviations during positioning.

The positioning accuracy takes the following characteristic values into consideration:

- ▶ Position deviation
- ▶ Reversal range
- ▶ Position variation range

Position deviation P_a

The position deviation corresponds to the maximum difference arising in the mean values of all the measurement points. It describes systematic deviations.



Reversal range U



The reversal range corresponds to the difference in mean values of the two approach directions. The reversal range is determined at every measurement point. It describes systematic deviations.

Position variation range P_s

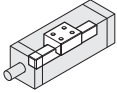
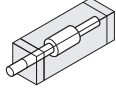
The position variation range describes the effects of random deviations. It is determined at every measurement point.

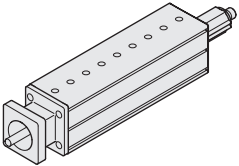
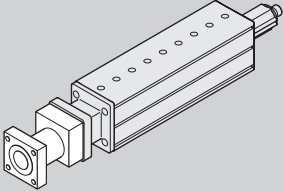
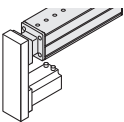
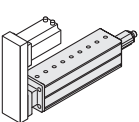
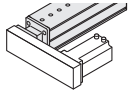
Ordering example VKK-100

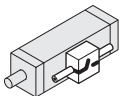
Short product name, length VKK-100-NN-1, mm		Guideway	Drive			Carriage					
Version				BASA size d ₀ x P			without adapter flange	with adapter flange			
				Screw journal	20x5	25x10	20x20				
With BASA, without motor mount	OF01	OF01		Ø 14	01	02	03	03	04		
	Ø 14 key-way			11	12	13					
with BASA and motor mount	MF01	MF01		L = 280 mm 12				03	04		
	L = 320 mm 13										
	L = 400 mm 15			Ø 14	01	02	03				
	L = 520 mm 18										
with BASA and timing belt side drive	RV01	RV01 to RV04		L = 600 mm 20	Ø 14	01	02	03	03	04	
	RV02										
	RV03										
	RV04										

Motor attachment			Motor		Cover		Switch		Documentation		
Gear ratio $i =$	Attachment kit	for motor	without	with	without	with				Standard report	Measurement report
			brake		bellows						
	00	-	00								
1	03	MSM 041B	130	131	00	01	without switch	00	01	02	03
	05	MSK 050C	88	89			Magnetic field sensor: - Reed sensor 21 - Hall sensor (PNP NC) 22				
1	27	MSM 041B	130	131	00	01	Magnetic field sensor with connector:	58	01	05	
	28						- Reed sensor - Hall sensor (PNP NC) 59				
1	29	MSK 050C	88	89	00	01			01		
1.5	30										

Ordering example

Find your local contact person here:

www.boschrexroth.com/adressen

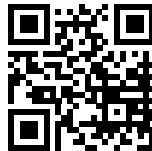

Feed module VKK-100-NN-1

Ordering data	Option	Explanation
Short product name	VKK-100	
Version	MF01	With motor mount for motor attachment
Guideway	15	Integrated ball rail system; L = 480 mm
Drive	02	Ball screw drive BASA size $d_0 \times P = 25 \times 10$
Carriage	04	with adapter flange
Motor attachment	05	For MSK motor 050C
Motor	89	MSK motor 050C with brake
Cover	01	with bellows
Switch 1	21	Reed sensor
Switch 2	22	Hall sensor, PNP NC
Switch 3	21	Reed sensor
Documentation	01	Standard report

Request or order

Bosch Rexroth AG
97419 Schweinfurt
Germany

To be completed by customer	Option
Request	
Order	

Ordering data	Option
Short product name	V K K - [] [] [] N N - 1
Version =	[] [] [] []
Guideway =	[] []
Drive =	[] []
Carriage =	[] []
Motor attachment =	[] []
Motor geometry code ¹⁾ =	[] [] - [] [] - [] [] [] - [] [] [] - [] [] [] - M [] [] - [] [] [] - [] [] []
Motor =	[] []
Cover =	[] []
Switch 1 =	[] []
Switch 2 =	[] []
Switch 3 =	[] []
Documentation =	[] []

1) Only required for "attachment kits for motors according to customer specification".

Order quantity	Quantity
One-off	[] [] []
Monthly	[] [] []
Annually	[] [] []
Per order	[] [] []
Comments	

From	
Company	
Address	
Name	
Department	
Fax	
E-mail	

Additional information

Bosch Rexroth homepage:

<http://www.boschrexroth.com>



Feed Modules VKK product information

<http://www.boschrexroth.com/de/de/produkte/produktgruppen/lineartechnik/linearsysteme/vorschubmodule/index>

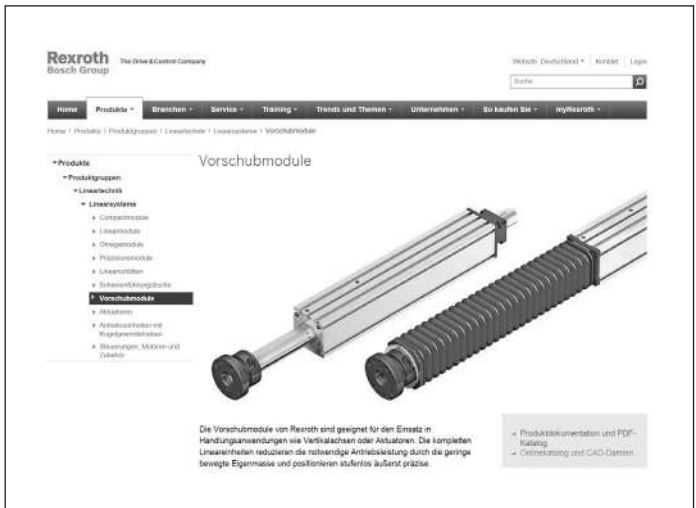

Notes

Bosch Rexroth AG

Ernst-Sachs-Straße 100
97424 Schweinfurt, Germany
Tel. +49 9721 937-0
Fax +49 9721 937-275
www.boschrexroth.com

Find your local contact person here:

www.boschrexroth.com/contact